

INSTRUCTION BOOK

Marine Diesel Engines

TAMD61/62/63/71/72

Structure of this Instruction Book

The first part of this Instruction Book contains important information on functions, fuel, oils and coolants. The operating instructions are important even if you know what you are doing. They may contain some information which is different to what you are used to. Read the first section before your first foray with your engine.

The rest of the manual – “Technical description and maintenance” – can be read once you have had time to acquaint yourself with your boat. This section will give you more information on the design and operation of your engine. Here you will also find a kind of “Do-It-Yourself” description of many aspects of maintenance.

Contents

Safety precautions	2	Maintenance	
General information	4	Periodic maintenance	23
Running-in	4	Maintenance schedule	25
Warranty and guarantee	5		
Certificated engines	6		
Introduction	7	Technical description	
Instrumentation	10	Engine	31
Key switch, starter keys	12	Lubrication system	34
Controls	12	Fuel system	38
Fuel, lubricating oils, coolant	14	Cooling system	42
		Electrical system	49
		Wiring diagrams	55
		Inhibiting	62
Operation		Launching	62
Before starting	15	Bringing out of storage	62
Starting the engine	16	Troubleshooting	63
Checks during operation	18	Technical data	66
Maneuvering during operation	18	Accessories	71
After operation	19		
When there is a danger of freezing	21		

Safety Precautions

Introduction

This Instruction Book contains the information you will need to operate the engine correctly. Check that you have the correct Instruction Book for your engine.

Read the book carefully before operating or servicing the engine. Incorrect operation or servicing of the engine could result in personal injury or material damage as well as damaging the engine itself. **If you do not understand or are uncertain on any operation in this book, contact your dealer who can explain or demonstrate the procedure for you.**

Important

In this book and on the engine you will find the following special warning symbols.

 **WARNING!** Possible danger of personal injury, damage to property or mechanical malfunction if the instructions are not followed.

 Read the Instruction Book.

Below is a summary of the risks and safety precautions you should always observe or carry out when operating or servicing the engine.

 Check that the warning or information labels on the engine are always clearly visible. Replace labels which have been damaged or painted over.

 Always turn the engine off before starting service procedures. Avoid burns. Take precautions to avoid hot surfaces and liquids in supply lines and hoses when the engine has been turned off immediately prior to starting work on it and it is still hot.

Reinstall all protective parts removed during service operations before starting work on the engine. Make a point of familiarizing yourself with other risk factors, such as rotating parts and hot surfaces (exhaust manifold, turbocharger, charge pipe, starter heater etc.).

Approaching an engine which is operating is a safety risk. Loose clothing or long hair can fasten in rotating parts and cause serious personal injury.

If the service operation requires that the engine is operating let your Penta authorized dealer carry out the work. If working in proximity of an engine which is operating, careless movements or a dropped tool can result in personal injury.

 Immobilize the engine by turning off the power supply to the engine at the main switches (breakers) so it is impossible to start, and lock the switches (breakers) in the OFF position before starting work. Set up a warning notice at the engine control point or helm.

 Never start the engine without installing the air cleaner. The rotating compressor parts in the Turbo can cause serious personal injury. Foreign objects entering the intake ducts can also cause mechanical damage.

 Engines with intake air pre-heating: Never use starting spray in the intake. Use of such products could result in an explosion in the air intake pipe due to the pre-heater. Danger of personal injury.

 Do NOT open the filler cap or vent nipples for the engine coolant when the engine is hot. Steam or hot coolant can be ejected and the pressure built up will be lost. Open the filler cap slowly and release coolant system pressure, if the filler cap or a drain cock/venting cock must be opened, or if a plug or engine coolant line must be removed on a hot engine. Steam or hot coolant can be ejected.

 Stop the engine and close the bottom valve before carrying out operations on the cooling system.

 Only start the engine in a well-ventilated area. If operating the engine in a closed area ensure that there is exhaust ventilation leading out of the work area to remove exhaust gases and crankcase ventilation emissions.

 Anti-corrosion agents are hazardous to health. Read the instructions on the product packaging!

 Anti-freeze agents are hazardous to health. Read the instructions on the product packaging!

 Certain engine conservation oils are inflammable. Some of them are also dangerous if breathed in. Ensure good ventilation in the work place. Use a protective mask when spraying.

 Hot oil can cause burns. Avoid getting hot oil on the skin. Ensure that the lubrication system is not under pressure before carrying out any work. Never start or operate the engine with the oil filler cap removed, otherwise oil could be ejected.

 Never allow an open flame or electric sparks near the battery area. Never smoke in proximity to the batteries. The batteries give off hydrogen gas during charging which when mixed with air can form an explosive gas. This gas is easily ignited and highly volatile. Incorrect connection of the battery can cause sparks sufficient to cause an explosion with resulting damage. Do not shift the connections when attempting to start the engine (spark risk) and do not lean over any of the batteries. Refer to instructions in the Instruction Book.

 Always ensure that the Plus (positive) and Minus (negative) battery leads are correctly installed on the corresponding terminal posts on the batteries. Incorrect installation can result in serious damage to the electrical equipment. Refer to the wiring diagrams.

 Always use protective goggles when charging and handling the batteries. The battery electrolyte contains extremely corrosive sulfuric acid. If this should come in contact with the skin, immediately wash with soap and plenty of water. If battery acid comes in contact with the eyes, immediately flush with copious amounts of water and obtain medical assistance.

 Turn the engine off and turn off the power at the main switches (breakers) before carrying out work on the electrical system.

 Clutch adjustments, where a clutch is fitted, must be carried out with the engine turned off.

 Use the lifting eyes fitted on the engine/reverse gear when lifting the drive unit. Always check that the lifting equipment used is in good condition and has the load capacity to lift the engine (engine weight including reverse gear and any extra equipment installed).

To ensure safe lifting and avoid damage to components installed on the top of the engine use an adjustable lifting beam. All chains and cables must run parallel to each other and as perpendicular as possible to the upper side of the engine.

If extra equipment is installed on the engine which alters its center of gravity a special lifting device is required to obtain the correct balance for safe handling.

Never carry out work on an engine suspended on a hoist.

 The components in the electrical system and in the fuel system on Volvo Penta products are designed and manufactured to minimize risks of fire and explosion.

Using parts that are not Original Volvo Penta parts which do not correspond to the demands above, can result in fire or explosion on board. Any type of damage which is the result of using replacement parts that are not original Volvo Penta replacement parts for the product in question will not be covered under any warranty or guarantee provided by AB Volvo Penta.

 Fuel filter replacement should be carried out on a cold engine in order to avoid the risk of fire caused by fuel spillage on the exhaust manifold. Always cover the alternator, if it is located under the fuel filter. The alternator can be damaged by spilled fuel.

 Always use protective gloves when detecting leaks. Liquids ejected under pressure can penetrate the body tissues and cause serious injury. Danger of blood poisoning.

 Always use fuels recommended by Volvo Penta. Refer to the Instruction Book. Use of fuels that are of a lower quality can damage the engine. On a diesel engine poor quality fuel can cause the actuating rod to hang and the engine to overrev with resulting risk of damage to the engine and personal injury. Poor fuel quality can also lead to higher maintenance costs.

 Observe the following when cleaning with high-pressure water jets. Never point the water jet at seals, rubber hoses or electrical components. Never use high pressure jets when washing the engine.

General Information

Welcome aboard

Thank you for choosing a Volvo Penta marine engine.

Volvo Penta have been building marine engines since 1907. Quality, operating reliability and innovation have made Volvo Penta a world leader in the marine engine industry.

As owner of a Volvo Penta marine engine we would also like to welcome you to a worldwide network of dealers and service workshops to assist you with advice, service requirements and spare parts. Please contact your nearest authorized Volvo Penta dealer for assistance.

We would like to wish you many pleasant voyages.

AB VOLVO PENTA

Technical Information

Your new boat

Every new boat has its own special characteristics. Even experienced boat owners are advised to note carefully how the boat behaves at different speeds, weather conditions and loads. If your boat and engine combination permit high-speed use, we strongly recommend that a safety breaker is fitted, regardless of the type of boat. If your boat is not fitted with a safety breaker contact your Volvo Penta dealer who can assist you in selecting one.

Running-in

When the engine is new, it should be run normally. However, full loading should be avoided for more than brief periods during the first ten hours of use. **Unnecessary idling of an unloaded engine should always be avoided.**

Check the instrumentation extra carefully during this period so that any abnormal conditions may be discovered in good time.

Check also that there are no leaks. See also under the heading "New engine with reverse gear", page 23.

Fuel and lubricants

Only use lubricants and fuels recommended under "Technical Data". Use of other classifications can cause malfunctions and reduced service life.

Spare parts



WARNING! The components in the electrical system and in the fuel system on Volvo Penta products are designed and manufactured to minimize the risk of fire and explosion.

Using parts that are not Original Volvo Penta parts and which do not correspond to the demands above, can result in fire or explosion on board. Any type of damage which is the result of using replacement parts that are not original Volvo Penta replacement parts for the product in question will not be covered under any warranty or guarantee provided by AB Volvo Penta.

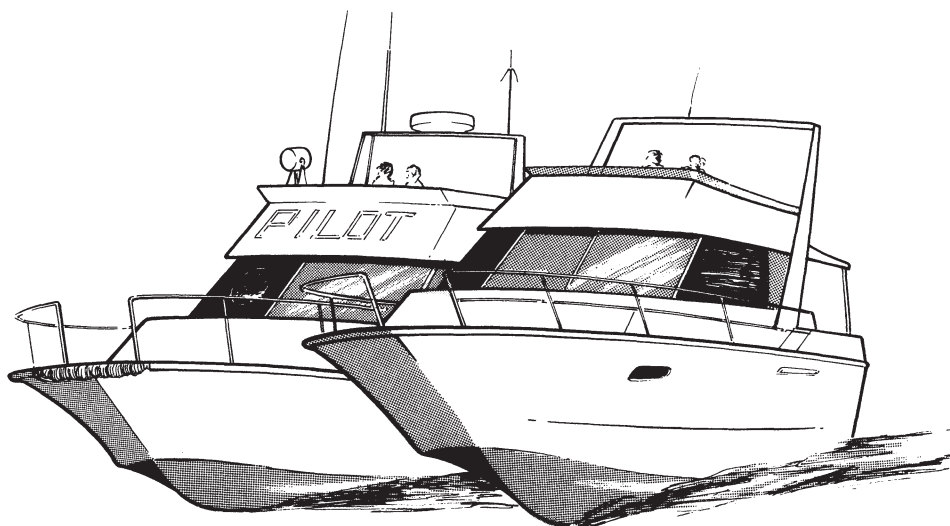

Safety

Everyone wants and expects to have a problem-free and pleasant time when they take their boat out. To help you do this we have provided a check-list below which can of course be added to according personal experience. A major area is naturally the engine, its equipment and that the boat in general is properly maintained.

Planning your trip

- Get out up-to-date charts for the route planned.
- Calculate distance and fuel consumption.
- Note down if there are fuel points on your planned course.
- Tell friends or relatives about your trip plans.

Boat equipment

- Rescue and emergency items such as lifevests and signal rockets. Does everyone know where they are?
- Spare parts on board, for example: Kit with water pump impeller etc.
- Proper tools for the equipment.
- Fire extinguisher (checked and charged).

Our joint responsibility

Volvo Penta continually commits a considerable part of its development resources towards minimizing the environmental impact of its products. Examples of areas where we are always looking for improvements are; exhaust emissions, sound levels and fuel consumption.

Regardless of whether your Volvo Penta engine is installed in a boat used for pleasure or in commercial operation, incorrect operation or improper maintenance of the engine will result in disturbance or damage to the environment.

In this instruction book there are a number of service procedures, which, if not followed will lead to a deterioration of engine characteristics with regard to how it effects the environment, its service life and cost of operation. Always follow the recommended service intervals and make a habit of checking that the engine is operating normally every time you use it. One example is excessively smoky exhaust. Contact an authorized Volvo Penta workshop if you cannot correct the fault yourself.

Bear in mind that most of the chemicals used around boats are harmful to the environment if used incorrectly. Volvo Penta recommends the use of bio-degradable degreasing agents for all cleaning. Always dispose of engine and transmission oil waste, old paint, degreasing agents and cleaning residue etc. at proper disposal areas so they do not harm the environment.

Adapt speed and distance during your boat trips so that swell and noise generated by the boat do not disturb or harm wildlife, moored boats, landing stages etc. Wherever you land or cruise, please show consideration and always leave the areas you visit as you would like to find them yourself.

Warranty and guarantee

A Service and Warranty book with conditions for Volvo Penta's International Limited Warranty is supplied with every engine. Contact your nearest Volvo Penta dealer or importer for your copy if you have not received one.

Some markets can have other warranty conditions depending on national legislation and regulations. These conditions are provided by the Volvo Penta importer or distributor for the market in question. If you wish to have a copy of the conditions please contact your local Volvo Penta representative.

Warranty Registration Card

The Warranty Registration Form (North American market) or Warranty Card (other markets) should always be filled out and sent in by the vendor. Make sure that this has been done, since refusal of warranty can occur if no proof of the delivery date can be provided.

Maintenance and care

- **PDC (Pre-Delivery Commissioning)** delivery undertaking for marine engines: "PDC" enables us to ensure that Volvo Penta products operate correctly after installation in a boat, and further that the end-user gets acquainted with the product, its functions and care (refer to the Warranty and Service book). Delivery undertaking "PDC" is carried out at the time of the delivery of the boat to the end-user. The cost of this work is covered by the Volvo Penta International Limited Warranty.
- **First Service Inspection:** A first Service Inspection must be carried out after operating the engine 100 hours (62, 63, 72) or 150–300 hours respectively (61, 71) or within 180 days from the delivery date, or the end of the first season, whichever occurs first. Labor and material costs in connection with the First Service Inspection are **not** covered by the Volvo Penta International Limited Guarantee (for checklist see your Warranty and Service book).

Regular maintenance should be carried out after the First Service Inspection in accordance with the maintenance scheme in this book. Any work carried out in addition to maintenance services should be documented (refer to the Warranty and Service book).

It is an absolute condition for the Volvo Penta International Limited Warranty to apply that the Pre Delivery Commissioning and First Service Inspection have been carried out by an authorized Volvo Penta service dealer.

Volvo Penta Service

Volvo Penta has a comprehensive dealer network that offers both service and spare parts for Volvo Penta engines. Volvo Penta dealers are carefully selected and then trained in order to provide customers with professional assistance on engine service and repairs. These dealers have the special tools required to carry out the work and the test equipment that ensures a high service standard. They are required to keep a stock of Volvo Penta Original Spare Parts and accessories that cover most requirements. When ordering service or spare parts always quote the complete engine and/or reverse gear model designation and serial number. These are stated on the engine product plate and on a label on the protective cover over the fuel injection pump coupling (see page 8).

- The engine may not be altered or modified in any way, with the exception of accessories and service kits developed by Volvo Penta for that engine.
- No modifications to the exhaust pipes and air supply ducts for the engine room (ventilation ducts) may be undertaken as this may effect exhaust emissions.
- Any seals on the engine may not be broken other than by authorized persons.



IMPORTANT! Use only VOLVO PENTA original spare parts. **The use of spare parts other than VOLVO PENTA original spare parts will invalidate AB VOLVO PENTA's responsibility for the engine specification being in accordance with the certificated variant.** VOLVO PENTA accepts no responsibility or liability for any damage or costs arising through the use of replacement parts other than original VOLVO PENTA replacement parts for the product in question.

Certificated engines

Important information for engines certificated for Lake Constance and Switzerland

All Volvo Penta engines and products are developed to minimize environmental impact.

National and regional legislation is not identical in all the markets where Volvo Penta sells its products. Occasionally legislation requires that we build special engine variants, or that an engine must be approved in advance, that is, certificated by the local authorities.

An engine with certification means that we, as the manufacturer, guarantee that all engines manufactured are of the same type as the certificated and approved example. Certification is not only a requirement covering engines from the factory, but also that engines in use must meet the environmental demands set for that engine. In order for Volvo Penta as the manufacturer to take responsibility for engines in use, certain requirements pertaining to service and spare parts must be met. We do not wish to discourage owners from carrying out service work themselves, rather the opposite since an owner can quickly notice if an engine is not operating normally. However, a number of service operations demand access to special expertise, workshop manuals, special tools and other equipment designed for the engines. These service operations may only be carried out by an authorized Volvo Penta Service workshop. Always contact your Volvo Penta dealer if you are not sure about anything concerning your engine's function or maintenance.

As an owner or operator of a certificated Volvo Penta engine it is important that you are aware of the following:

- The Service Intervals and maintenance operations recommended by Volvo Penta must be followed.
- Only Volvo Penta Original Spare parts intended for the certificated engine may be used.
- Service work on the injection pump and injectors or pump settings must always be carried out by an authorized Volvo Penta workshop.

Identifying Numbers

Immediately after you have taken delivery of your boat, make a note of the serial number and model designation of the engine and reverse gear. Include the serial number and model designation of the boat and any extra equipment. This information is necessary when you contact your Volvo Penta or boat sales representative for service and spare parts. Take a copy of the information and keep it in a safe place so it is available should the boat be stolen.

Engine type

Serial No.

Reverse gear type

Serial No.

Disengageable clutch type

Serial No.

Propeller designation

Boat type

Serial No.

Other equipment

Serial No.

Introduction

TAMD61, 62, 63, TAMD71, 72

These engines are directly injected, four-stroke, straight six marine diesel engines equipped with turbochargers, charge air coolers (aftercoolers) and heat exchangers for thermostat-controlled freshwater cooling.

The charge air cooler (aftercooler), which is seawater-cooled, lowers the temperature of the inlet air to the engine after compression in the turbocharger. This creates the conditions for high power output while keeping the combustion and exhaust gas temperatures to an appropriate level.

TAMD61, TAMD62, TAMD71: To reduce exhaust emissions when operating at low load, e.g. after (cold-) starting, there is a bypass valve which closes the air passage through the

charge air cooler (aftercooler) and instead channels the air directly into the engine's inlet manifold via the electrical pre-heating element.

This equipment is not necessary in the TAMD63 and TAMD72, which have, *inter alia*, higher compression, a different combustion chamber, and a modified injection system.

The exhaust manifold and turbocharger are freshwater-cooled to reduce the radiant heat to the engine compartment.

For a more detailed description of the engine, its fuel, lubrication, and cooling systems, etc., see under "Technical description" on pages 27–48.

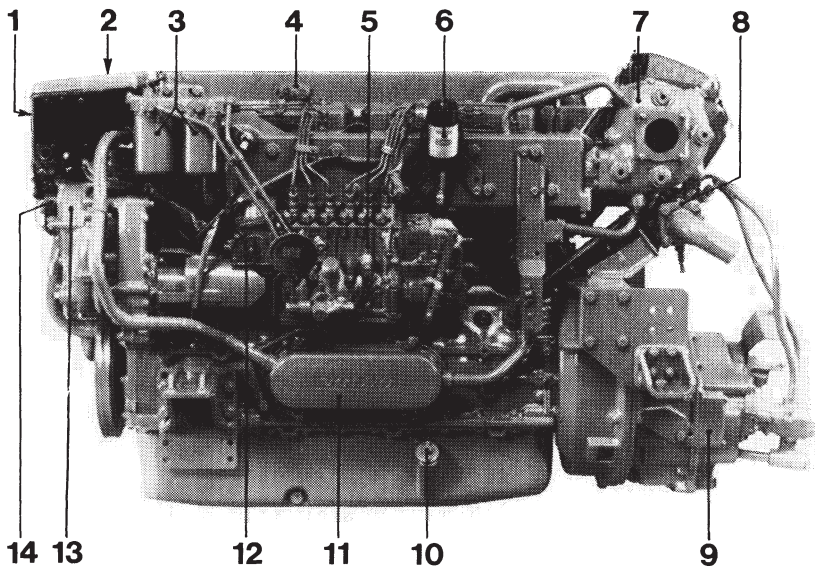

Fig. 1. TAMD61A

1. Terminal box with semi-automatic fuses
2. Coolant filler cap
3. Fine fuel filters
4. Oil filler cap
5. Injection pump
6. Stop solenoid
7. Turbocharger
8. Oil cooler, reverse gear
9. Reverse gear MPM IRM 220A
10. Alt. pos. of oil dipstick
11. Oil cooler, engine
12. Smoke limiter
13. Circulation pump
14. Alternator

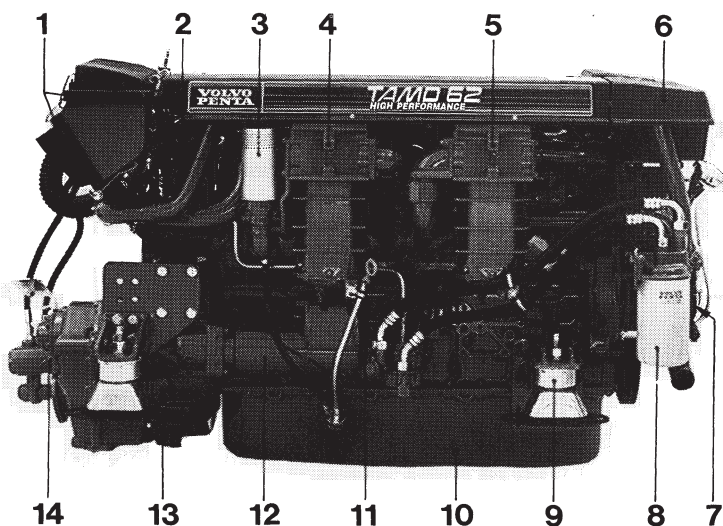

Fig. 2. TAMD62

1. Air filter
2. Bypass valve (controls the flow of air through the charge air cooler)
3. Filter for crankcase ventilation
4. Charge air cooler (aftercooler)
5. Heat exchanger
6. Expansion tank
7. Seawater pump
8. Lubricating oil filter, engine (alt. located at the back of the left-hand side of the engine as an accessory)
9. Flexible engine mounting (accessory)
10. Oil sump
11. Oil dipstick
12. Starter motor
13. Reverse gear MPM IRM 220A-1
14. Oil dipstick, reverse gear

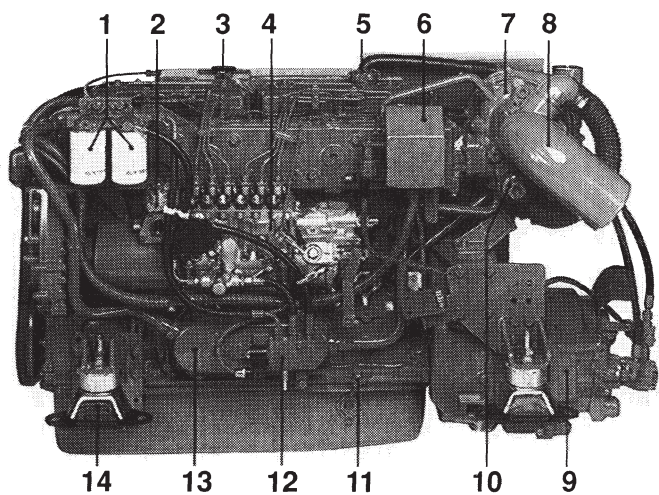
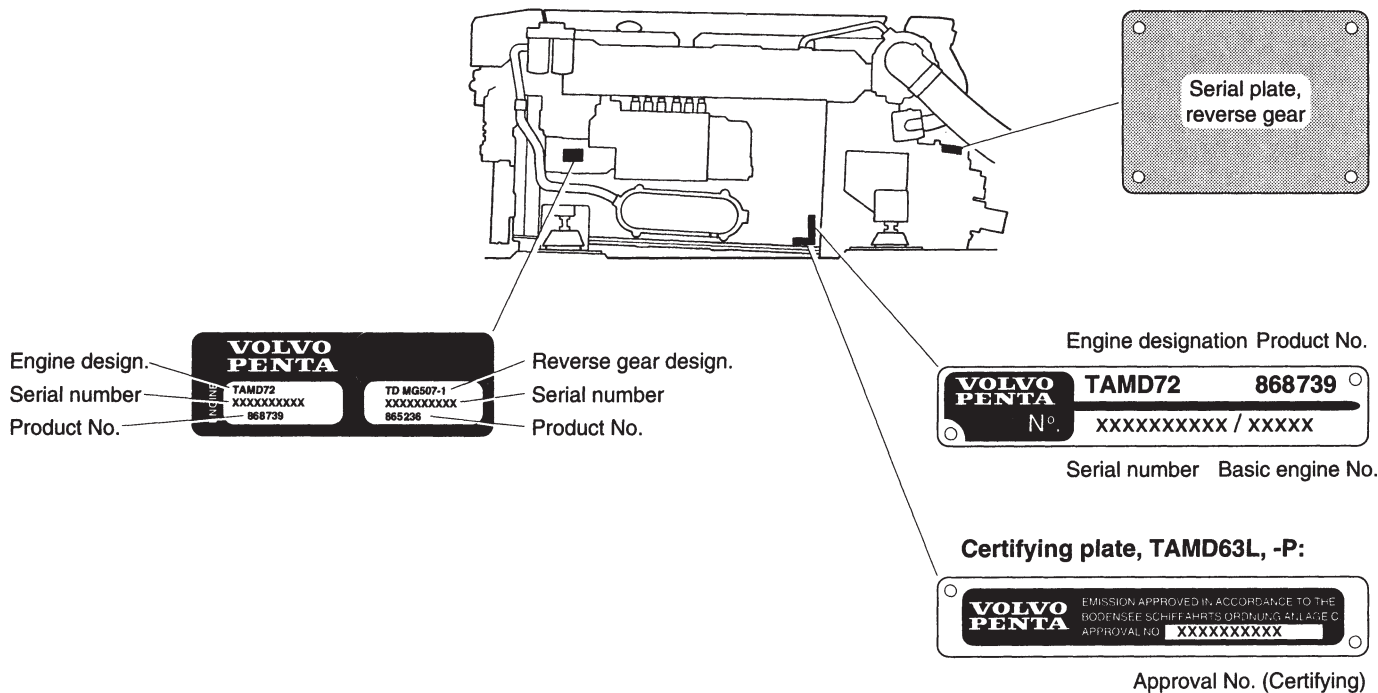

Fig. 3. TAMD63L, TAMD63P

1. Fine fuel filters
2. Smoke limiter
3. Coolant filler cap
4. Injection pump
5. Oil filler cap
6. Terminal box with semi-automatic fuses
7. Turbocharger
8. Water-cooled exhaust bend (accessory)
9. Reverse gear MPM IRM 220A-1
10. Wastegate valve (by-pass valve)
11. Oil dipstick, engine
12. Solenoid valve (direction valve) for stopping engine
13. Oil cooler, engine
14. Flexible engine mounting (accessory)

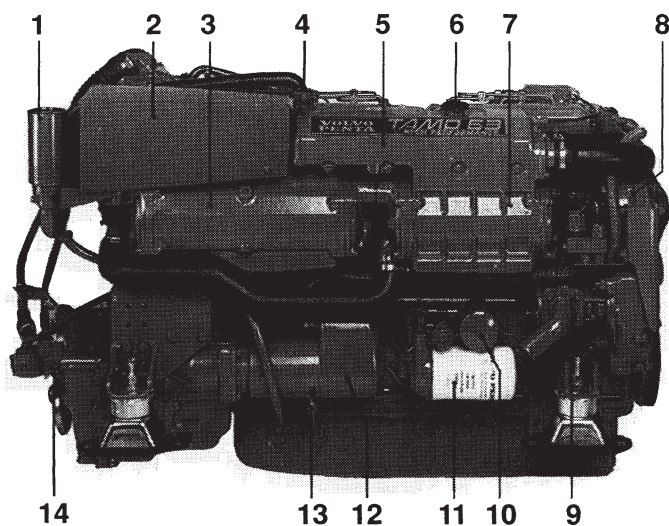

Fig. 4. TAMD63P

1. Filter for crankcase ventilation
2. Air filter
3. Charge air cooler (aftercooler)
4. Oil filler cap
5. Expansion tank
6. Coolant filler cap
7. Heat exchanger
8. Alternator
9. Seawater pump
10. Bypass filter for lubricating oil
11. Lubricating oil filter, engine
12. Starter motor
13. Oil dipstick, engine
14. Oil dipstick, reverse gear

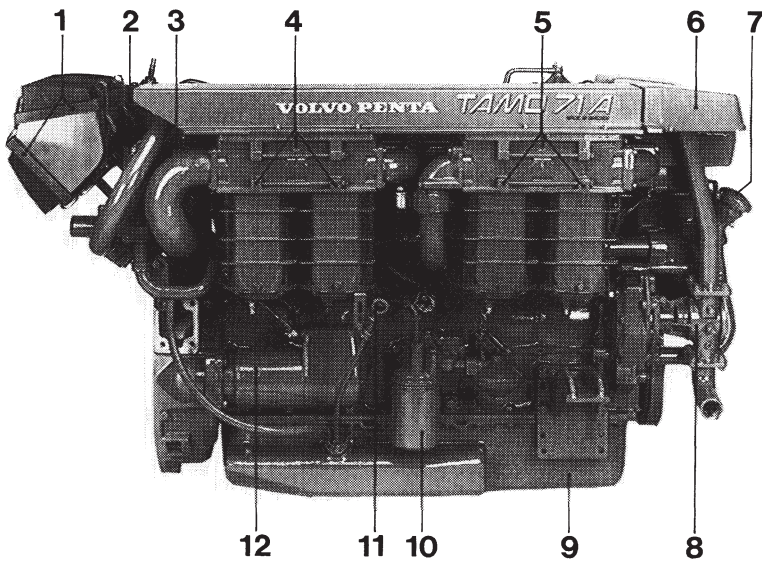

Fig. 5. TAMD71A (auxiliary engine)

1. Air filter
2. Filter for crankcase ventilation
3. Bypass valve (controls the flow of air through the charge air cooler)
4. Charge air cooler (aftercooler)
5. Heat exchanger
6. Expansion tank
7. Oil filler cap (accessory)
8. Seawater pump
9. Oil sump
10. Lubricating oil filter
11. Oil dipstick
12. Starter motor

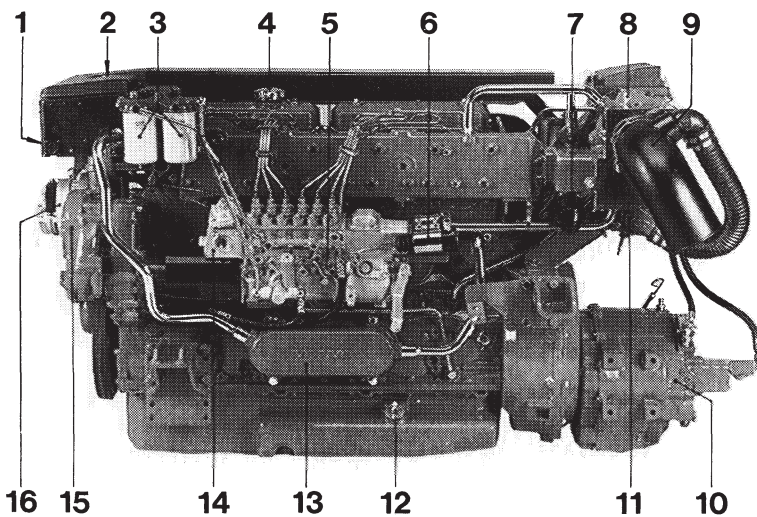

Fig. 6. TAMD72

1. Terminal box with semi-automatic fuses
2. Coolant filler cap
3. Fine fuel filters
4. Oil filler cap
5. Injection pump
6. Stop solenoid
7. Wastegate valve (by-pass valve)
8. Turbocharger
9. Water-cooled exhaust bend (accessory)
10. Reverse gear TD MG5061SC
11. Oil cooler, reverse gear
12. Alt. location of oil dipstick
13. Oil cooler, engine
14. Smoke limiter
15. Circulation pump
16. Alternator

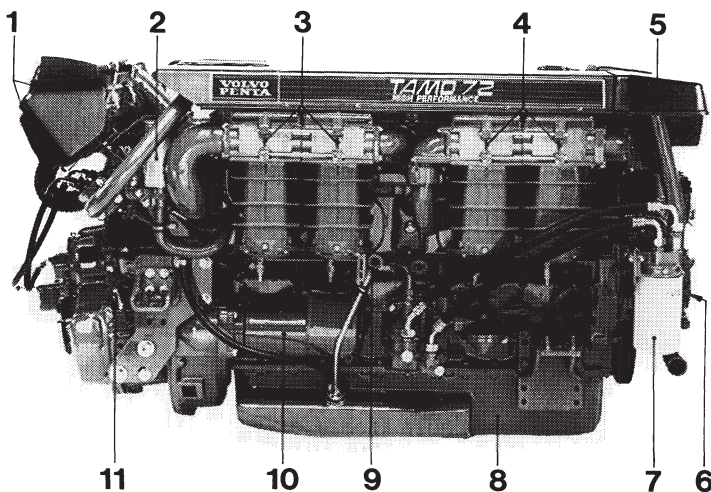
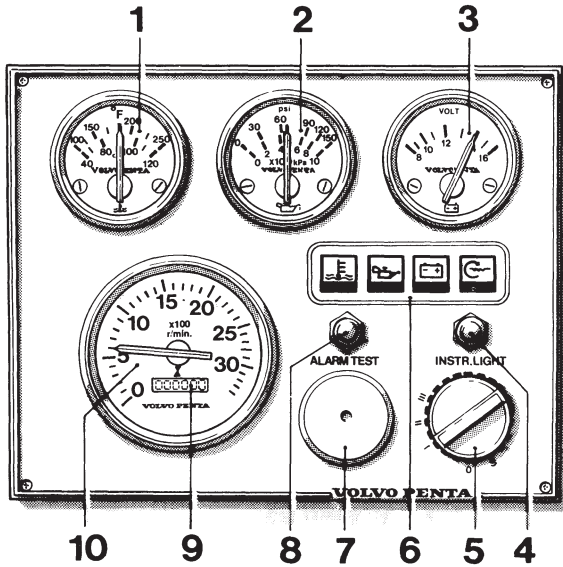

Fig. 7. TAMD72

1. Air filter
2. Filter for crankcase ventilation
3. Charge air cooler (aftercooler)
4. Heat exchanger
5. Expansion tank
6. Seawater pump
7. Lubricating oil filter, engine (alt. located at the back of the left-hand side of the engine as an accessory)
8. Oil sump
9. Oil dipstick
10. Starter motor
11. Oil dipstick, reverse gear TD MG507A-1

Instrumentation

The instrument panels used are the main panel, the Flying Bridge (instrument panel for alt. control position) and the auxiliary panel. The instrumentation is also supplied separately in sets if Volvo Penta instrument panels are not used. These sets include three smaller panels for starting, stopping and alarm functions.



Main panel

1. Coolant temperature gauge.
2. Oil pressure gauge, engine.
3. Voltmeter. Displays the voltage in the starter battery circuit.
4. Pressure switch for instrument lighting.
5. Key switch (start lock) with start and stop functions and a built-in restart inhibitor (starter motor guard).
The restart guard means that new attempts to start can be made only once the key has been returned to the stop position (S).
6. Alarm panel with warning symbols (pos. 11–14).
7. Alarm (siren) for fault alerts. Sounds when lubricating oil pressure is too low (engine), when coolant temperature is too high or there is a loss of charge.
8. Pressure switch for testing alarm functions or acknowledging alarms.
 - **No alarm:** Alarm test (all warning lights shine steadily and the siren sounds).
 - **Alarm:** Alarm acknowledgement.*
9. Hours run meter. Displays the engine's operating time in hours and tenths of an hour.
10. Tachometer, engine speed. Multiply the value by 100 for revolutions per minute.

*The siren goes off, but the warning light continues to flash until the fault has been rectified. If a new alarm condition occurs, the siren sounds again and the next warning lamp starts to flash, and so on.

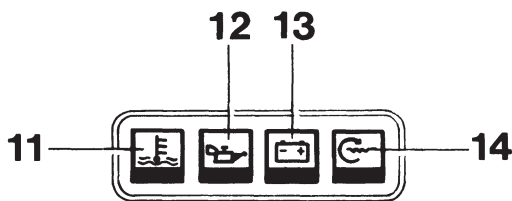

Alarm panel

This panel has four "windows". If the acoustic alarm comes on, one of the windows "11–13" starts to flash (red) to show the cause of the alarm.

11. Warning light – high coolant temperature.
12. Warning light – low lubricating oil pressure, engine.
13. Warning light – comes on if the charging current from the alternator stops.
14. Indication lamp – preheating on (starter element).*

N.B.: This light also works as a filament guard for the starter element.* This light will shine even when the key switch is in the I position (operating position) if there is a fault in the starter element (break).

***N.B.:** TAMD63 and TAMD72 have no starter element.

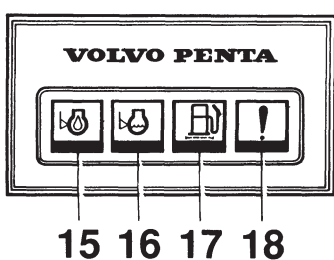

Extra alarm panel

This panel has four "windows". If the acoustic alarm comes on, one of the windows starts to flash (red) to show the cause of the alarm.

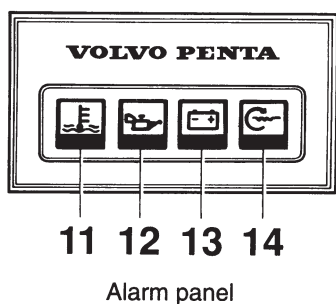
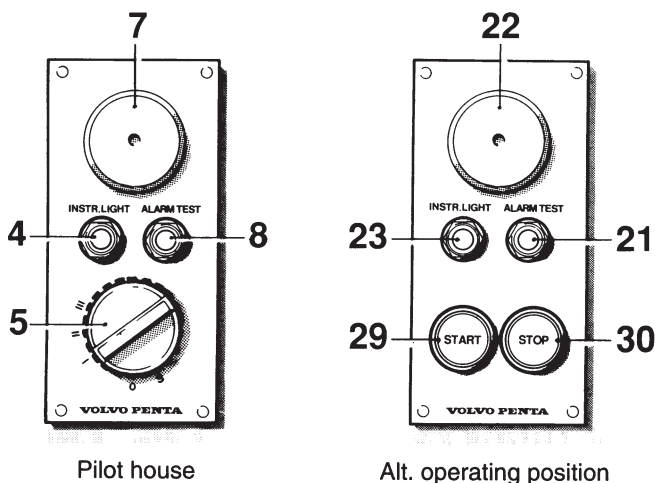
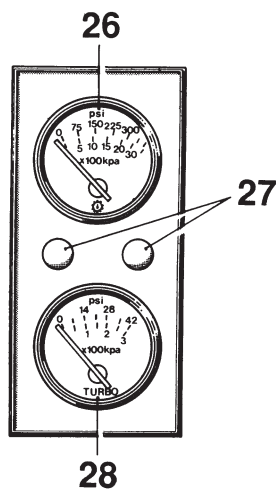
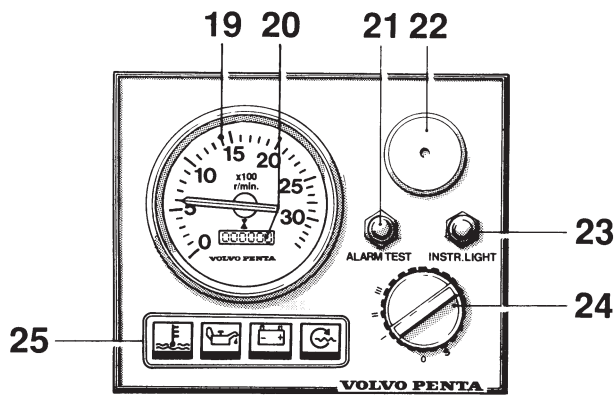

15. Lubricating oil level too low. Top up to correct level before starting.
16. Coolant level too low. Top up to correct level before starting.
17. Water in extra pre- fuel filter. Drain off water in filter. See maintenance schedule on page 25 (item 12).
18. Extra alarm.

“Flying Bridge” (instrument panel for alt. control position)

19. Tachometer, engine speed. Multiply this value by 100 for revolutions per minute
20. Hours run meter. Displays the engine’s operating time in hours and tenths of an hour.
21. Pressure switch for testing alarm function.
22. Alarm for fault alerts, corresponding to same in main panel.
23. Pressure switch for instrument lighting.
24. Key switch (start lock) with start and stop functions and a built-in restart guard (starter motor guard).
The start lock means that new attempts at ignition can be made only once the key has been returned to the stop position (S).
25. Alarm panel with warning symbols corresponding to same in main panel.

Auxiliary panel

26. Oil pressure gauge for reverse gear.
27. Blind plugs. Space for (e.g.) extra switch.
28. Manometer for turbocharger’s charging pressure.

Instrument sets

The instrumentation is also supplied separately in sets. These sets include the following three smaller panels for starting and stopping and for utilising the alarm functions.

Control panel for pilot house (main panel)

Control panel for alt. operating position

N.B.: The key switch in the pilot house control panel must be in position I (operating position) for starting to be carried out from the alt. operating position.

Engines with a starter element: The starter element may be engaged only via the key switch on the panel in the pilot house.

29. Starter button. The starter motor is engaged when this button is pressed. Release the button as soon as the engine has started.
30. Stop button. The stop solenoid or stop valve is engaged when this button is pressed.

Alarm panel

The alarm panel has warning symbols corresponding to those in the main panel (pos. 11–14).

Controls

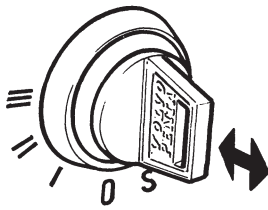

Key switch

The key switch has five positions, including 0:

Pos. 0 = The key can be inserted and taken out.

S = Stop position (stop solenoid or stop valve engaged). The key springs back automatically to the 0 position after stopping.

I = Operating position. The key springs back automatically to the operating position after preheating or starting.

II = Preheating position (starter element engaged).*

III = Starting position (starter motor engaged).

See also instructions for starting.

*N.B.: TAMD63 and TAMD72 have no starter element.

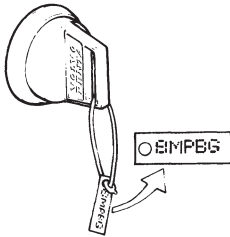

Starter keys

The starter keys are tagged with a key code. Use this code when ordering new keys. Do not keep the tag on your boat. The code must not be divulged to unauthorized persons.

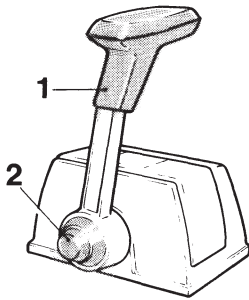

VP single control

Lever (1) for reversing maneuvers and controlling engine speed

Pos. N – neutral position

From N to F – reverse gear engaged for forward motion

From N to R – reverse gear engaged for reverse motion

T – affects engine speed

Disengaging reverse gear from the control:

Push the button (2) when the lever is in neutral, then push the lever forwards. The lever can then be used as a throttle control with the reverse gear disengaged. **Take care not to engage reverse gear by mistake.**

The reverse gear is engaged automatically when the lever is moved back to the neutral position.

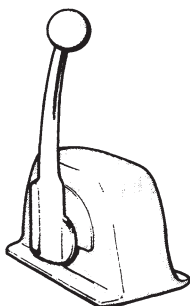

Type S control for maneuvering trolling valve

Controls

Volvo Penta uses two types of controls: single lever and dual lever. With single lever controls, both acceleration and reverse gear maneuvers are controlled using one lever, while the dual lever controls have a separate lever for each function.

Single lever controls

Volvo Penta single lever controls have functions for acceleration and reverse gear maneuvers all in one lever. When starting, for example, the gearing function can simply be disengaged so that only the engine speed is affected by the lever. When maneuvering the boat forwards or backwards, at the moment of changing gear the lever mechanism makes the engine speed drop to idling.

The control lever has an adjustable friction brake. A neutral contact which allows the engine to be started only when the reverse gear is disengaged is available as an accessory.

A dual single lever control is available for use with double engines.

Single lever controls with a single function are suitable for controlling a trolling valve*, if fitted. One of these is the type S control.

*The trolling valve is an accessory for the Twin Disc reverse gear MG507(A)-1.

Dual lever controls

These controls have separate levers for acceleration and gearing. A mechanical lock means you can shift only when the acceleration lever is in the idling position. The controls have a neutral contact to prevent starting with the reverse gear engaged. Both control levers have separately adjustable friction brakes.

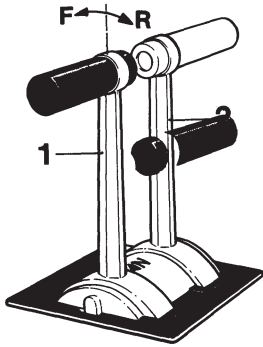

VP dual controls

1. Lever for reverse gear maneuvers (black handle)
Pos. N – neutral position
From N to F – reverse gear engaged for forward motion
From N to R – reverse gear engaged for reverse motion
2. Lever for controlling engine speed (red handle)

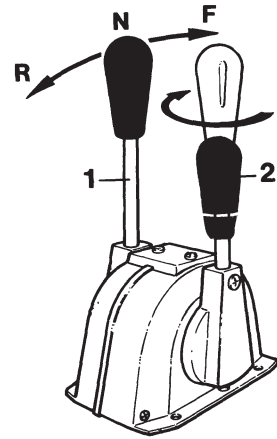

NB dual controls

1. Lever for reverse gear maneuvers (black handle)
Pos. N – neutral position
From N to F – reverse gear engaged for forward motion
From N to R – reverse gear engaged for reverse motion
2. Lever for controlling engine speed (red handle)
One brake can be adjusted by turning this handle in order to counteract the regulator power.

Fuel, Oils, Coolant

Diesel

The composition of the fuel is vital for operation of the engine, its service life, and emissions. To meet the performance specified and to run your boat cleanly and quietly, it is vital that you use fuel as recommended below:

Diesel which meets the requirements of DIN-EN 590, ASTM-D975-No. 1-D, 2-D, or SS-EN 590 should be used.

The fuel should contain as little sulfur as possible.

Diesel sold by well-known oil companies for running road vehicles is as a rule suitable for marine purposes.

Lubricating oil, engine

A lubricating oil of a quality as shown in the table below should be used:

Designation	Standard
VDS*	Volvo Drain Specification
CD, CE	API (American Petroleum Institute)
MIL-L-2104D	US Government's Military Spec.

* A VDS oil must be used if there is to be a long period between oil changes. See also the maintenance schedule and "Technical Data".

We do not advise that you run on an oil of a quality which does not meet the above requirements. This is a poor solution with respect to both economy and operating safety.

For viscosity and capacities, see "Technical Data" on page 62.

Lubricating oil, reverse gear

For the reverse gear, a single grade oil of quality CC, CD or CE according to the API system should be used. Oil according to the MIL-L-2104D standard may also be used.

For viscosity and capacities, see "Technical Data" on pages 64-66.

Oil for servo unit system, hydraulic pump (accessory)

ATF oil* should be used in the servo unit system.

*ATF = Automatic Transmission Fluid (oil for automatic gearboxes).

Coolant

The engine's internal cooling system (freshwater system) is filled with a mixture of freshwater and additives. **N.B.: Never** use freshwater without additives. The following recommendations should be followed to prevent frost and corrosion damage to your engine:

When there is a chance of freezing

Use a mixture of 50% Volvo Penta antifreeze (glycol) and 50% pure water (as neutral as possible). **This mixture will protect against freezing to a temperature of approx. -40°C (-40°F) and should be used all year round.**

N.B.: There should be at least 40% antifreeze in the system for complete protection against corrosion.



N.B.: Glycol is harmful to health (do not drink!).

When there is no chance of freezing

When there is never any chance of freezing, water with added Volvo Penta anti-corrosive agent* (part No. 1141526-2) may be used if the water/glycol mixture is not used all year round. Mixture ratio = 1:30.

See the instructions on page 41 for how to top up coolant. Warm up the engine after filling to allow the additive to work as efficiently as possible.



N.B.: Anti-corrosive agents are harmful to health (do not drink!).

* **N.B.:** Never mix the anti-corrosive agent with antifreeze (glycol). Foam may form and seriously impair cooling.

Replacing the coolant

The coolant should be replaced and the system flushed at least once a year. See also the maintenance schedule.

Volvo Penta products

See also under the headings "Accessories" on page 67.



Operation

Before starting

1. Open the cooling water intake's sea cock.
2. Check that all the drain cocks are closed and all the drain plugs are fitted.
For the positioning of cocks/plugs, see the pictures on pages 21 and 22.

3. Open the fuel cocks.
4. Check that no fuel, water or oil is leaking out.

5. Check the coolant level. This should be approx. 5 cm (2") beneath the sealing surface of the filler cap, or between the MIN and MAX marks on the separate plastic expansion tank (accessory). For filling, see page 41.

 **Open the cap carefully if the engine is hot.**

6. Check the engine oil level. This should be within the area marked on the dipstick.
The oil level must never be lower than the bottom mark.

7. Check the oil level in the reverse gear.*
***N.B.:** Since the marks on the dipstick apply for operating temperature (with the engine idling and the control in neutral), the correct level before starting must be judged by experience.

8. Engage the main switches.

9. Check the amount of fuel.

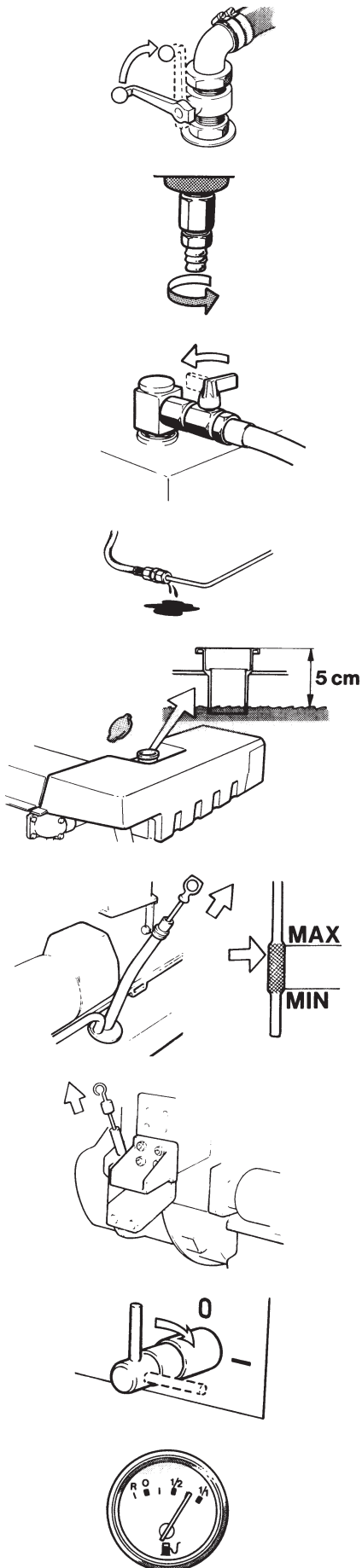

Starting the engine

To keep smoke on starting to a minimum, the TAMD61, 62 and TAMD71 are fitted with air preheating (a starter element). This starter element is found in the inlet manifold, and its rating is controlled by a time relay. For the TAMD63 and TAMD72, which have higher compression (*inter alia*), a different combustion chamber and a modified injection system mean that no starter element is necessary.

The starter element should be on for approx. 50 s for preheating the inlet air before cold-starting. After starting, the element is switched on automatically for a further 50 s to reduce exhaust smoke during warming up and to make the engine run evenly.

Warning! Never use starting spray or similar to help start engines with a starter element. The starter element may cause an explosion in the inlet manifold. Danger of injury.

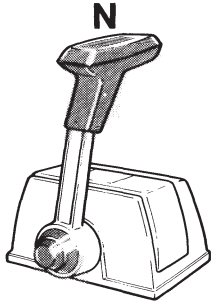

1. **Single lever control:** Check that the lever is in neutral "N". This means that the throttle control is set to idling and the reverse gear is disengaged.

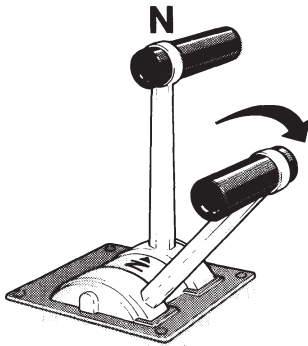

Dual lever control: Put the forward/reverse lever into neutral to start. Pull the throttle lever right back (idling position).

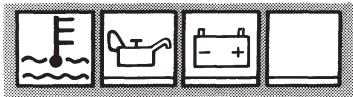
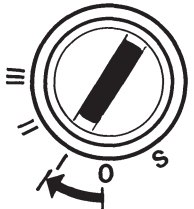

2. Put the key in the key switch. Turn it to the "I" position (operating position). All warning lights will come on and stay on for max. 20 s. The high coolant temperature warning light will then go off.

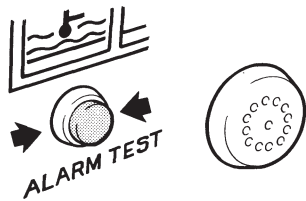

3. Push the "Alarm test" button and check that the alarm sounds (warning lights come on). The alarm will go off when the button is released.

4. Engines with a starter element

Cold engine: Turn the key to position "I" (preheating). Release the key when the "starter element on" indicator light comes on. This element should be on for approx. 50 s (time relay). Do not attempt to start the engine until the indicator light has gone out.

Hot engine: Turn the key directly to position "III" to start.

5. Turn the key to position "III" to start (after the indicator light has gone out in the case of engines with a starter element). Release the key as soon as the engine starts.

The key switch has a restart guard. The starting procedure must therefore always begin at the "S" position when making repeated attempts to start.

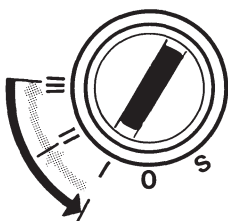
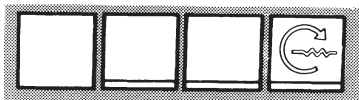
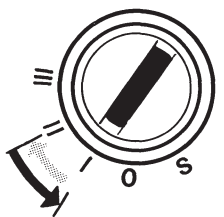

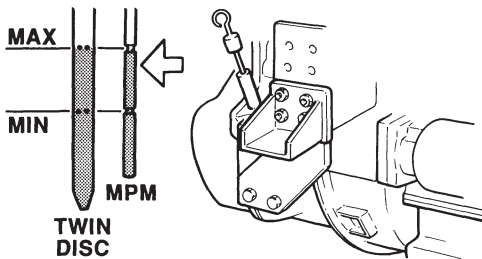
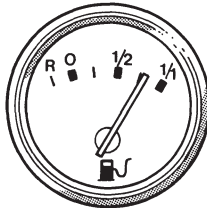
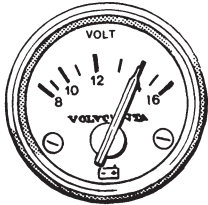
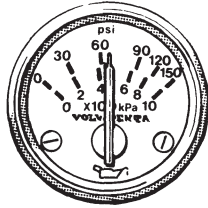
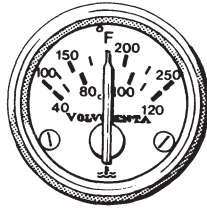
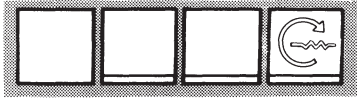

Engines with starter element: After starting, the “Starter element on” indicator light will remain on for approx. 50 s (afterheating).

Warm up the engine at low speed and low load. **Do not race the engine while it is cold.**

When warming up the engine, check that the instruments display normal values.

The needle on the temperature gauge should rise slowly up to operating temperature, 75–95°C (167–203°F).

At operating speed, the engine’s oil pressure gauge should show at least:

- 300 kPa (3.0 kp/cm² = 43 psi) – TAMD61, -62, -63.
- 420 kPa (4.2 kp/cm² = 61 psi) – TAMD71, -72.

The system voltage should be approx. 14V or 28V depending on whether the engine has a 12V or 24V electrical system.

The warning lights should be off* and the alarm silent.

* **Engines with starter element:** The preheating indicator light goes off approx. 50 s after starting.

Check the amount of fuel.

Check the oil level in the reverse gear when it has reached **operating temperature** (with the engine idling and the control in neutral). The oil level should reach the upper mark on the dipstick.

⚠ N.B.: Never break the circuit with the main switches while the engine is running. The voltage regulator and alternator may be seriously damaged.

The starter motor must **never** be engaged while the engine is running. The starter motor and starter gear on the flywheel may be seriously damaged.

Starting using auxiliary batteries

⚠ Warning!

The batteries (auxiliary batteries in particular) contain extremely explosive oxyhydrogen gas. One spark, which may be formed if the auxiliary batteries are connected incorrectly, is sufficient to explode a battery and cause damage and injury.

1. Check that the auxiliary batteries are connected (in series or in parallel) so that their rated voltage is the same as the engine’s system voltage.
2. First connect the red jump lead (+) to the auxiliary battery, then to the discharged battery. Then connect the black jump lead (–) to the auxiliary battery, then to a spot **short**

distance from the discharged batteries, e.g. at the main switch on the negative cable or at the negative cable’s connection to the starter motor.

3. Start the engine. **N.B: Do not displace the connections while attempting to start the engine (risk of sparks), and do not lean over any of the batteries.**
4. Remove the jump leads in exactly the opposite order to which you put them on. **N.B: The normal leads to the standard batteries should under no circumstances be moved.**

Checks during operation

Monitor the instruments. The normal operating values are:

Coolant temperature

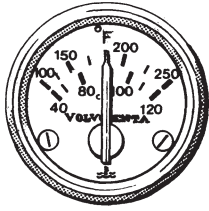

75–95°C (167–203°F)

Oil pressure, engine

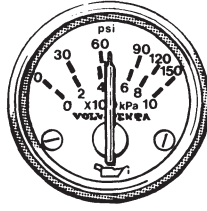

TAMD61, 62, 63: 300–550 kPa
TAMD71, 72: 420–650 kPa

System voltage

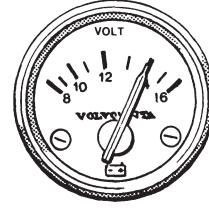

approx. 14V (12V) or
28V (24V)

If the oil pressure drops, the temperature rises above the permitted values or there is a loss of charge, the alarm will sound and one of the warning lights will start to flash to show what the alarm is for.

If the alarm sounds:

- High coolant temperature. **Reduce the speed to idling (in neutral) until the temperature drops. Investigate the cause of the alarm** (e.g. blocked engine water intake). **Stop the engine if the temperature does not drop.**
- Low lubricating oil pressure. **Stop the engine immediately and investigate the cause of the alarm.**

If an extra alarm panel is fitted, the alarm will also sound if the lubricating oil or coolant levels are too low before starting or if there is water in the extra fuel pre-filter. An extra alarm function may also be connected.

N.B.: If the engine is run continuously for long periods, its lubricating oil level must be checked at least every 8 hours with the engine stopped (you must wait for at least approx. 3 minutes before reading off the oil level).

Maneuvering during operation

In all respects, economical operation is achieved by not cruising faster than is necessary. **The recommended cruising speed is the maximum speed which can be achieved at any given time minus 200 r/min.**

All forward/reverse maneuvering should be done at idling speed. Maneuvering at higher speeds may damage the reverse gear and will also be uncomfortable for those on board. Maneuver as follows:

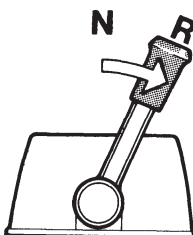
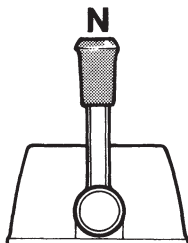
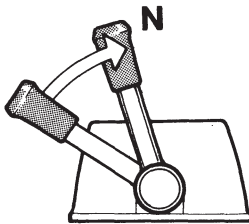

Reverse gear

1. Drop the speed to idling and, if possible, let the boat lose most of its speed.
2. Move the reverse gear control lever quickly and firmly into the neutral position, then wait for a moment.
3. Move the control lever quickly and firmly into reverse, then increase the speed.

N.B.: If the boat has two engines, it is vital that both engines are running, particularly when maneuvering forwards and backwards. If one engine has not been started and the other is used to reverse, water may enter the switched-off engine via the exhaust port and cause serious damage.

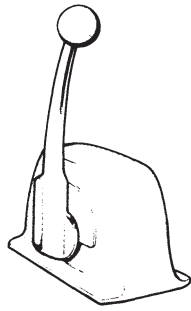

Type S controls for maneuvering trolling valve

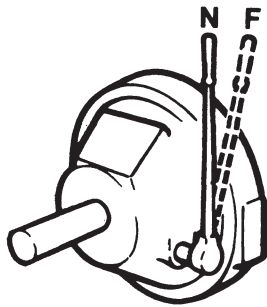

Disengageable clutch

F = Engaged
N = Neutral

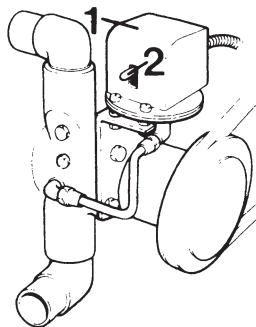

Bilge pump

1. Vacuum switch
2. Actuating lever

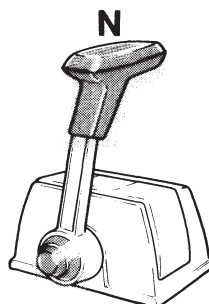
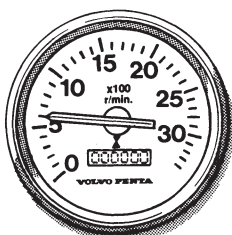

N.B.: The equipment shown on this page can be obtained only for propulsion engines in working boats.

Trolling valve (Twin Disc MG507-1 and MG507A-1)

If the reverse gear has a trolling valve (accessory), this should be used when the boat is to move very slowly.

Engage the trolling valve to max. slip when the reverse gear control is in neutral. After selecting "Forward" or "Reverse", the trolling valve can then be set in the required trolling position within the permitted speed range.

⚠ The engine speed must never exceed 1100 r/min. when using the trolling valve.

N.B.: For full propeller power during operation, the trolling valve control lever should always be in the "Disengaged" position when the valve is not in use.

Disengageable clutch (accessory, TAM71A)

The clutches have two positions on the control lever. Lever towards engine for declutching, away from it for neutral. **When engaging and disengaging the clutch, the engine speed must not exceed 800 r/min.**

Disengageable scavenging/bilge pump (accessory, TAM71A, 24V)

These pumps are engaged and disengaged via electromagnetic connections and switches on the instrument panel. The bilge pump has a vacuum switch which automatically disengages it when the level is so low that no water is being sucked into the pump. The vacuum switch also has a lever for manually engaging the pump.

This lever should be pressed in for approx. 20 s when engaging the pump.

After operation

1. Let the engine idle for a few minutes with the reverse gear in neutral after landing. This will even out the engine temperature and prevent local overheating which may cause the coolant to boil.

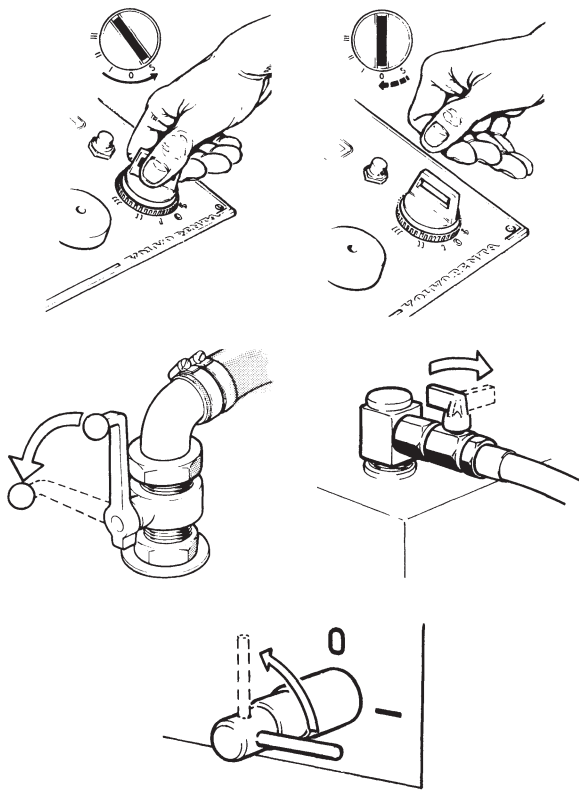

2. Turn the key to stop position "S". Release the key when the engine has stopped (key will spring back automatically into the 0 position). The key can then be taken out.

Safety measures:

3. Close the cooling water intake sea cock and the fuel cocks. See also under the heading "Action when there is a risk of freezing" on the next page.

4. Switch off the main switches if the boat is not to be used for some time.

5. Inspect the engine and engine compartment for any leaks.

Propeller shaft brake

Under certain operating conditions, the propeller may make the propeller shaft rotate when the engine is stopped. This rotation may damage the reverse gear since its oil pump, which is driven by the integral shaft, stops when the engine stops.

The propeller shaft may be allowed to rotate for 24 hours when the engine is stopped (Twin Disc) or approx. 6–8 hours (MPM). However, it is expedient, if possible, to run the engine for a brief period every 8 hours or so in order that the reverse gear may be lubricated and cooled (Twin Disc).

If the shaft may rotate more quickly than during normal oper-

ation, e.g. during sailing, a temperature gauge should be fitted which monitors the temperature of the oil.

The max. permitted temperatures are 110°C (230°F) for Twin Disc and 95°C (203°F) for MPM reverse gears.

Where it is impossible to comply with the above mentioned regulations, a shaft brake must be fitted (or, in individual cases, the propeller shaft flange can be disconnected at the reverse gear).

Action when there is a risk of freezing

Check the antifreeze in the freshwater system after the engine has stopped if there is a risk of freezing. See under the heading "Coolant" on page 14.

Drain the water from the seawater system as described below. Check that all the water has drained out.

Check the batteries as described on page 49. A poorly charged battery may easily burst as a result of freezing.

Draining coolant

Before draining the coolant, the engine should be stopped, the filler cap unscrewed and the boat's sea cock closed. Then open the drain cocks or remove the drain plugs of the engine's freshwater and seawater systems. See the figures below and on the next page.

Check that all the water has drained out. There may be deposits inside the cock/plug which must be flushed away, otherwise there is a risk that water may remain in the system and cause serious damage.

Check whether the installation has any more cocks or plugs on the cooling water and exhaust pipes' lowest points.

Remove the cover from the seawater pump and the cover on any extra pump.

Close the cocks, fit the plugs and put the cover on the seawater pump. **Pump out the boat if required. Ensure that there are no leaks before you leave the boat.**

See the instructions on page 41 for topping up the coolant.

TAMD61, TAMD62 and TAMD71, TAMD72

F = Freshwater cocks/plugs

S = Seawater cocks/plugs

V = Venting cock

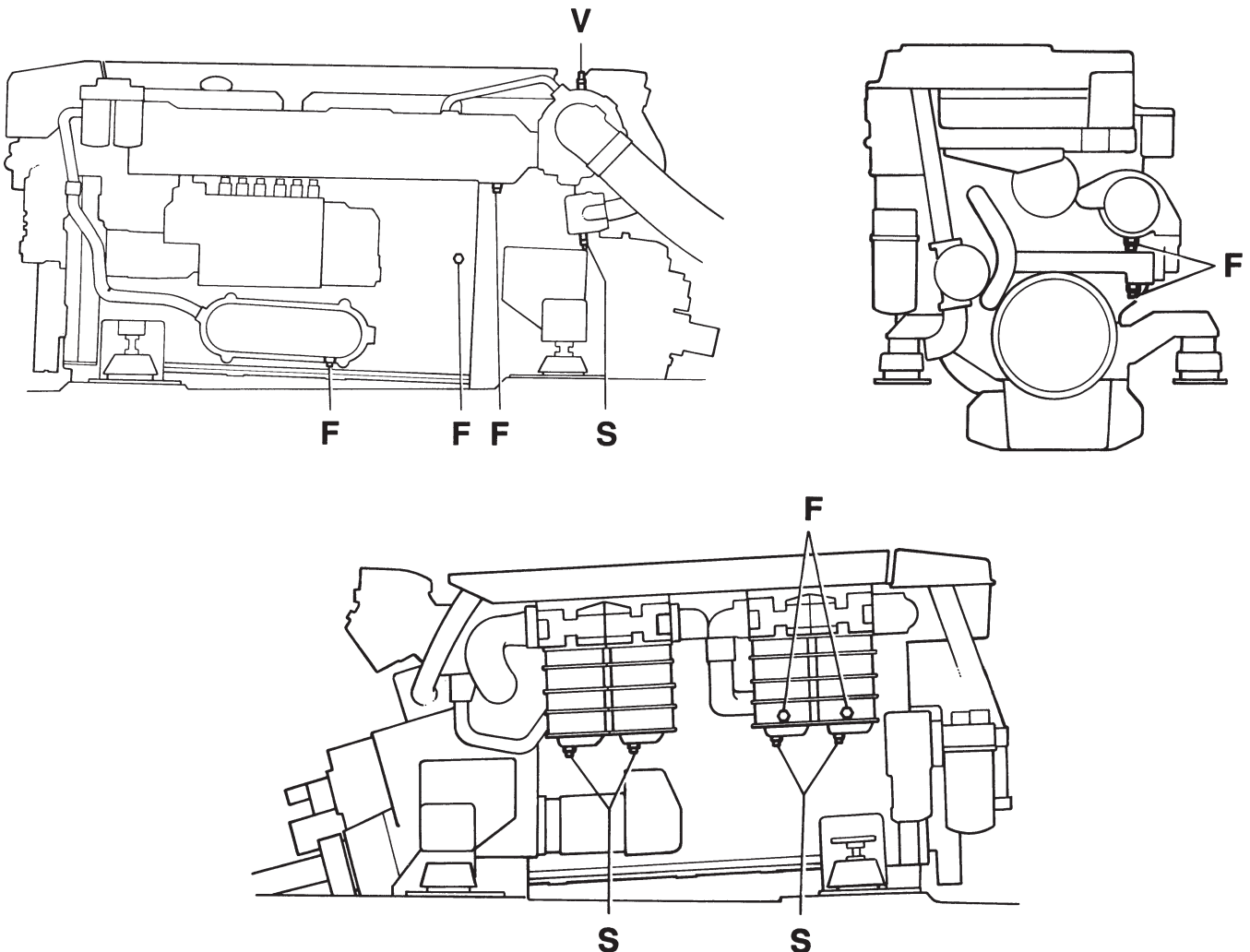

TAMD63

N.B.: Remove the cover on the seawater pump. Also remove the hose between the heat exchanger and the reverse gear's oil cooler, then drain off the coolant while draining the seawater system.

F = Freshwater cocks/plugs

S = Seawater cocks/plugs

V = Venting cock

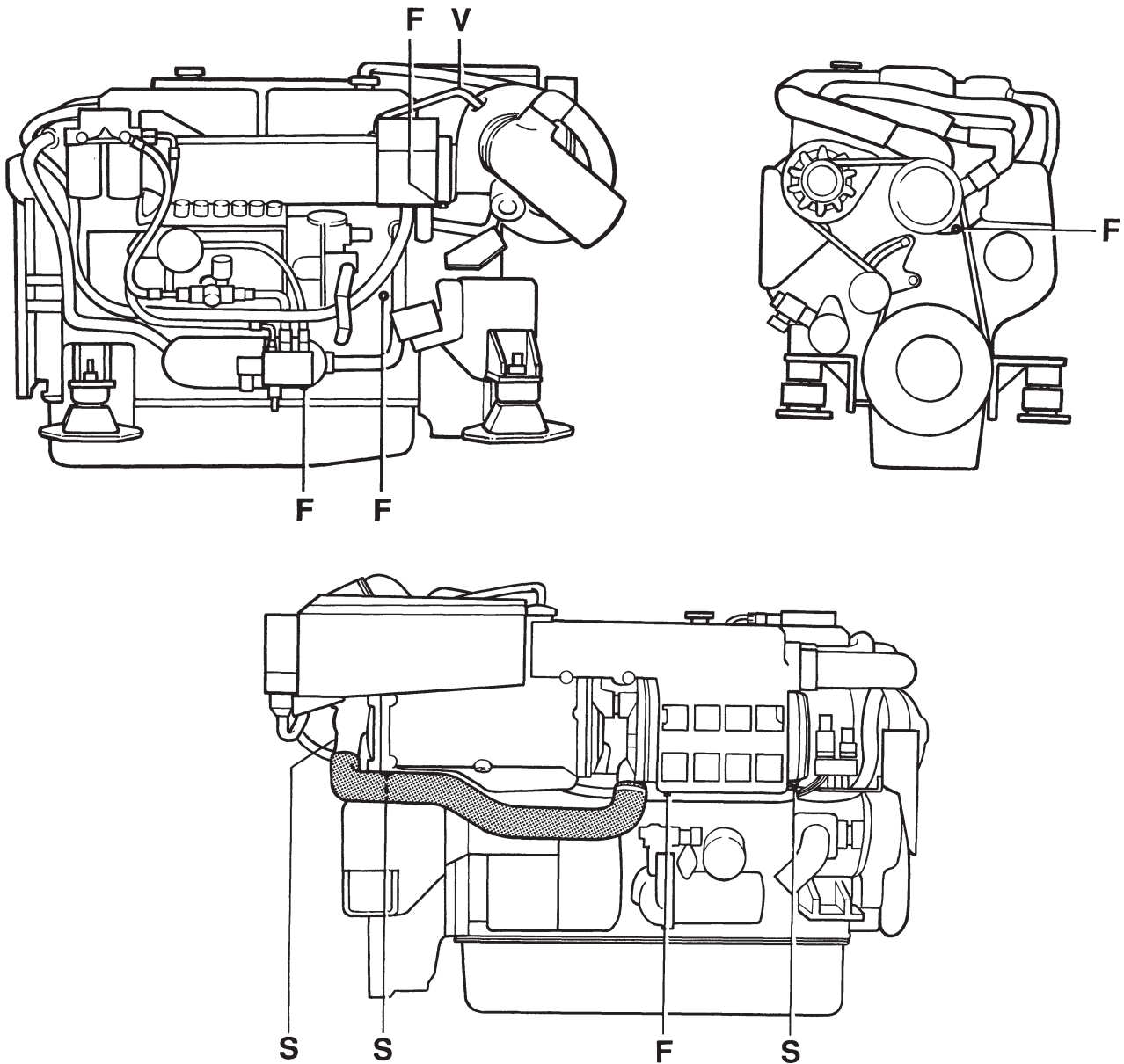

Periodic maintenance

If your engine and its fittings are to work perfectly, periodic maintenance in accordance with the maintenance schedule is required. Several of the items deal with the replacement of wear parts such as oil filters, fuel filters, etc.

To ensure continued trouble-free use of your engine, it is important always to use original spares. Always state the type designation and serial number of your engine and its fittings when ordering parts.

Some operations require professional experience and special tools. Therefore, get authorized service personnel to carry out more extensive work.

For further information, see under the heading "Maintenance" in acc. with the respective section in "Technical Description".

New engine with reverse gear

N.B: With a new or reconditioned engine, the valve clearance should first be checked after 150 hours of operation.

The oil and oil filter* in the Twin Disc reverse gear should first be changed at this point too. Remove and clean the reverse gear's oil screen at the same time. In the case of MPM reverse gears, the oil screen should be cleaned after 10 and 50 hours of operation, and the first oil and filter change* should be made after 50 hours of operation.

The disengageable clutch should be checked more closely during the first few days. It may be necessary to adjust it to compensate for wear to the laminate.

*Only the TD MG507-1 and MG507A-1 with a trolling valve have an oil filter, as does the MPM IRM 301A.

Layout of the maintenance schedule

No.	Action	50 Hrs	100 Hrs	250 Hrs	500 Hrs	1000 Hrs	2000 Hrs	Instructions	Info. page.
1.	Replace engine oil. N.B.: See table above re. ratio of oil quality to replacement interval. 1) For TAMD62, 63 and TAMD72. 2) For other engines							VDS engine oil or CD or CE in acc. with API system. Drain or pump out oil while engine is hot. Warning! Hot oil can burn.	32
2.	Change oil filter (1) and any bypass filter (2) at every oil change.							Lubricate gasket and screw on new filter by hand. Tighten by hand once gasket is tight. Top up oil, start, check for leaks. Stop engine.	33
3.	Replace adjustable filter. (For TAMD71A auxiliary engine)							Hand in injectors to authorized service dealer (or replace with adjusted injectors). Tightening torques: injectors 50 Nm (5 kpm/37 ft.lb.), pressure pipes 15-25 Nm (1.5-2.5 kpm/11.1-18.5 ft.lb.). N.B.: TAMD63/TAMD72 pressure pipes must not be bent. Replace if damaged.	36
17.	Get authorized personnel to check injectors. 1) For TAMD62, 63, 71B and 72 2) For other engines.							Hand in injectors to authorized service dealer (or replace with adjusted injectors). Tightening torques: injectors 50 Nm (5 kpm/37 ft.lb.), pressure pipes 15-25 Nm (1.5-2.5 kpm/11.1-18.5 ft.lb.). N.B.: TAMD63/TAMD72 pressure pipes must not be bent. Replace if damaged.	37

* N.B.: Special recommendations apply for new or reconditioned engines. See instructions under heading "New engine with reverse gear" on page 23.

Shading denotes simpler operations which can be carried out by the boat owner himself.

Red denotes operations which require professional experience and/or special tools. This work should therefore be left to authorized service personnel.

Under the heading "**Instruction**" is a brief summary of what should be rectified when carrying out the maintenance job in question.

Under the heading "**Info. page**" are references to the information pages towards the back of the manual. In most cases, these pages provide a more detailed description of the operations required.

Preventive Maintenance

To achieve maximum operating safety and service life, it is vital to maintain the engine and its fittings in accordance with the maintenance schedule. This gives instructions on when and how to carry out maintenance. Always consult an authorized Volvo Penta service dealer, who will have the equipment and trained staff to help you.

For boats used for commercial purposes, there is also a program of preventive maintenance known

as "Condition Test", which is part of the "Cost Control Program". This program is carried out every 6 months, and every other time in accordance with an extended program.

A maintenance program well carried out gives better operating economy and fewer unplanned periods of non-operation.

Engine, oil change intervals

Dependent on the fuel's sulfur content and the quality of the lubricating oil

N.B.: However, the oil should always be changed at least once a year even if the operating times in the table are not achieved.

Engine	Oil quality	Fuel sulfur content, % by weight	
		<0.5	0.5-1.0
TAMD61 and TAMD71 TAMD62, TAMD63 and TAMD72	VDS*	Hours 500	Hours 250
	VDS*	200	100
TAMD61 and TAMD71 TAMD62, TAMD63 and TAMD72	API: CD or CE	250	125
	API: CD or CE	100	50

*VDS = "Volvo Drain Specification"

- A.* Engine lubricating oil. Filler cap.
- B. Terminal box with semi-automatic fuses. Push the button if a fuse has tripped.
- C. Coolant. Cap for filling and checking.
- D. Fine fuel filters.
- E. Air filter.
- F. Alternator.
- G. Lubricating oil, reverse gear. Filler cap.
- H. Filter for crankcase ventilation.

- I. Lubricating oil filter, engine (alt. locat. rear of engine's left side).
- K. Heat exchanger.
- L. Oil dipstick, engine.
- M. Charge air cooler (aftercooler).
- N. Oil dipstick, reverse gear (alt. locat. on left or right side, depending on type of reverse gear).
- O. Seawater pump.
- P. Bypass filter for lubricating oil.

* Also at front of engine TAMD71 in commercial boats and auxiliary engines (accessory).

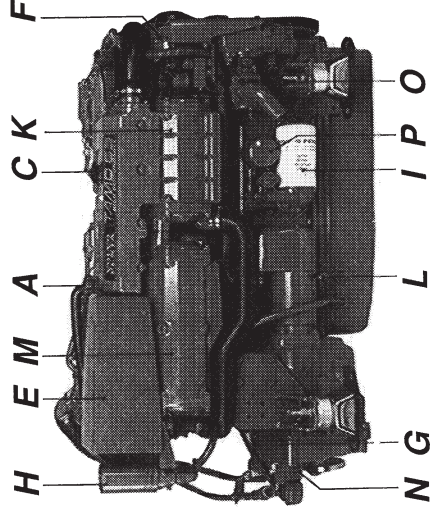
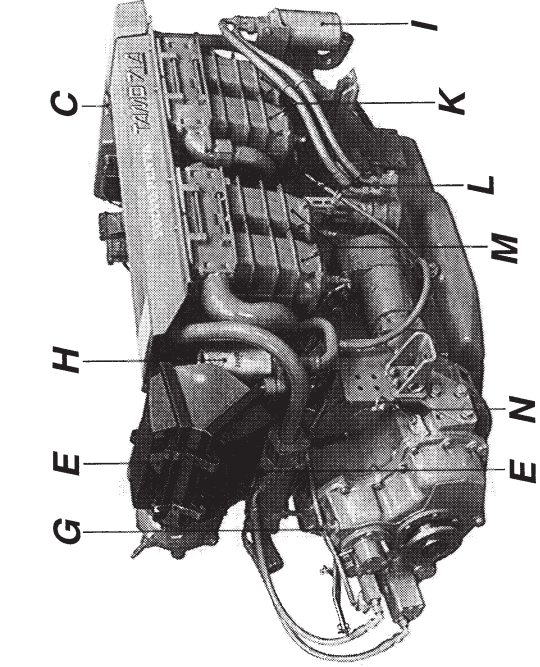
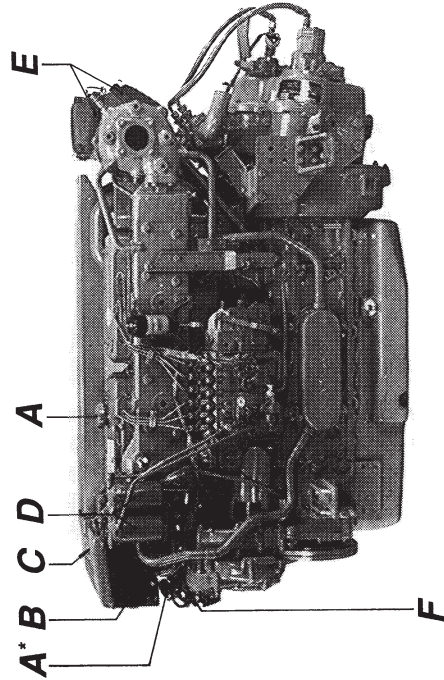

Maintenance Schedule

This description generally applies to all engines unless otherwise stated.

If longer intervals between replacements than those stated here are required, the condition of the oil must be checked by the oil manufacturer at regular lubricating oil tests.



The time intervals stated here are guidelines for normal operating conditions. For a new or reconditioned engine, see under heading "New engine with reverse gear" on page 23.



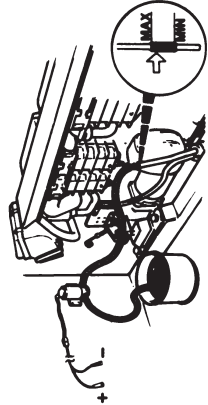
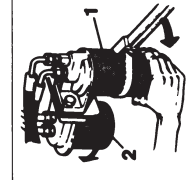
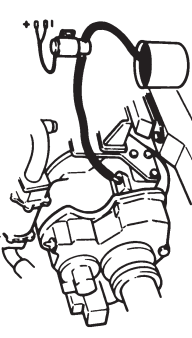
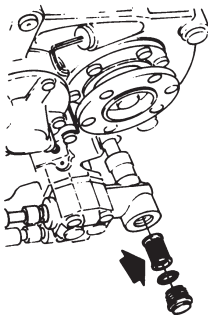
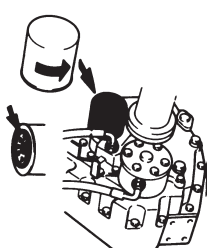
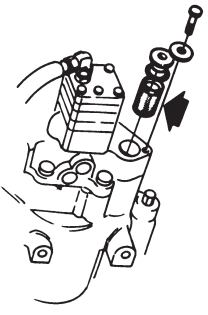

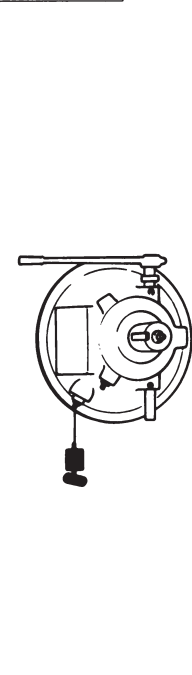
All the actions below, with the exception of points 17 and 32, should be carried out at least once a year even if the operating time in the schedule has not been achieved. Points 17 and 32 should be carried out at least once every two years.

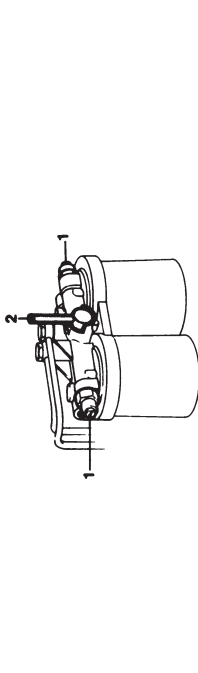
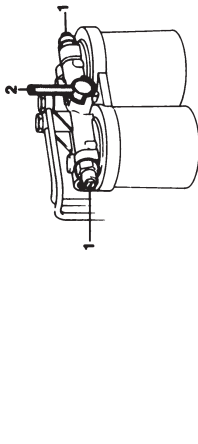
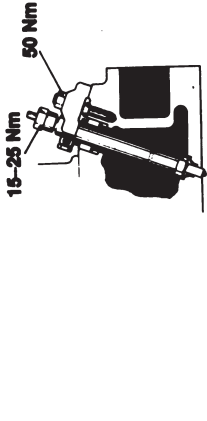
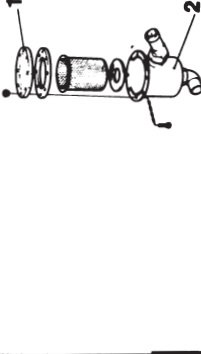

⚠ N.B.: Stop the engine before starting servicing (except for point 16)!

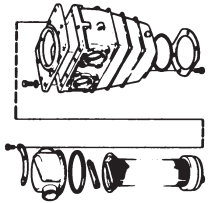
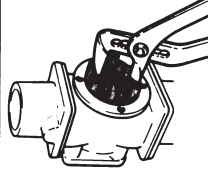
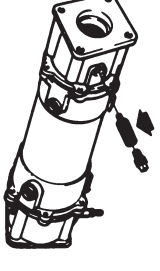
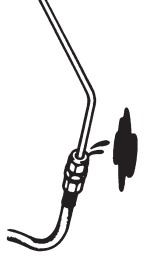
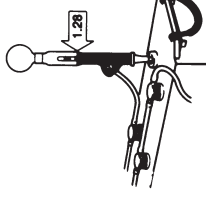
No.	Action	50 Hrs	100 Hrs	250 Hrs	500 Hrs	1000 Hrs	2000 Hrs	Instructions	Info. pge.
1.	Replace engine oil. N.B.: See table above re. ratio of oil quality to replacement interval. 1) For TAMD62, 63 and TAMD72. 2) For other engines	●	●	●				 <p>VDS engine oil or CD or CE in acc. with API system. Drain or pump out oil while engine is hot. ⚠ Warning! Hot oil can burn.</p>	32
2.	Change oil filter (1) and any bypass filter (2) at every other oil change.							 <p>Lubricate gasket and screw on new filter by hand. Tighten by 3/4 turn once gasket is tight. Top up oil, start, check for leaks. Stop engine and check oil level.</p>	32
3.	Replace oil in reverse gear.					●		 <p>Fill up with oil. Use CD, CE or CC engine oil, but not multigrade oil. For viscosity, see "Technical Data". Check oil level. N.B.: Marks on dipstick apply at operating temperature (engine idling and controls in neutral).</p>	33
4.	MPM reverse gear: Remove and clean reverse gear oil screen.			●				 <p>Remove plug and oil screen. Clean screen and refit parts. Start engine and check for leaks after filling with oil.</p>	33
5.	Replace oil filter in reverse gear MPM IRM 301 A.					●		 <p>Lubricate gasket and screw on new filter by hand. Tighten by 3/4 turn once gasket is tight. Top up oil. Start, check for leaks. Check oil level (see point 3 above).</p>	-
6.	Twin Disc reverse gear: Remove and clean reverse gear oil screen.					●		 <p>Remove plug and oil screen. Clean screen and refit parts. Start engine and check for leaks after filling with oil.</p>	33

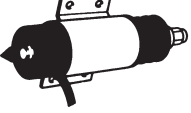
<p>7. Replace oil filter in reverse gear Twin Disc MG507(A)-1 with trolling valve.</p>	<p>Remove clamp (1). Remove cover and take out filter. Clean filter casing and fit a new filter. Check oil level (point 3 above).</p> 	<p>—</p>	<p>—</p>	<p>—</p>	<p>—</p>
<p>8. Lubricate release bearing on disengageable clutch (if fitted).</p>	<p>Lubricate sparingly so that no grease escapes. Use lithium-based lubricating grease: Mobilux EP2, Staitoil Uniway EP2N, Texaco Multifak EP2, O8 Rembrandt EP2.</p>	<p>—</p>	<p>—</p>	<p>—</p>	<p>—</p>
<p>9. Lubricate disengageable clutch (if fitted).</p>	<p>Lubricate inner support bearing (when a grease nipple is fitted), main bearings, disengaging shaft and moving parts of clutch. Lubricate sparingly (20–30 g for main bearings). Quality: see point 8 above. A few drops of oil on inner link arms.</p>	<p>—</p>	<p>—</p>	<p>—</p>	<p>—</p>
<p>10. Check/adjust disengageable clutch (if fitted).</p>	<p>⚠ Warning! Engine must be stopped when adjustment is carried out. Remove inspection cover. Release lock (A) and turn adjusting ring (B) clockwise (Rockford/BW) or counterclockwise (A.P.). Secure lock. The laminates must not slide after engagement.</p>	<p>—</p>	<p>—</p>	<p>—</p>	<p>—</p>
<p>11. Replace filter for crankcase ventilation. 1) For TAMD62, 63 and TAMD72. 2) For other engines.</p>	<p>Screw on the new filter by hand. N.B.: Replace filter earlier if air mixed with oil starts to escape via valve (1). Check that drainage hose (2) is not blocked.</p>	<p>—</p>	<p>—</p>	<p>—</p>	<p>—</p>
<p>12. Check/drain extra fuel filter.</p>	<p>A few hours after stopping: Drain off water or contaminants via cock/plug (1).</p>	<p>—</p>	<p>—</p>	<p>—</p>	<p>—</p>
<p>13. Replace insert(s) in extra coarse fuel filter.</p>	<p>Close fuel cocks at tank before dismantling single filter or if replacing the inserts of the double filter (engine off). See also instructions on page 32.</p>	<p>—</p>	<p>—</p>	<p>—</p>	<p>—</p>
<p>14. Replace fine fuel filters.</p>	<p>Screw on the new filters by hand. Tighten by 1/2 turn once gasket is tight. Cleanliness! No contaminants should be allowed to enter the fuel system. Vent system – see point 15 below.</p>	<p>—</p>	<p>—</p>	<p>—</p>	<p>—</p>

15.	Vent fuel system.		<p>Open vent screw (1). Pump with hand pump (2) until fuel containing no air flows out. Close screw while fuel is flowing out. Then pump a further 10–20 times. Check for leaks.</p> 	37
16.	Replace adjustable fuel filter. (For TAMD71A auxiliary engine)			36
17.	Get authorized personnel to check injectors. 1) For TAMD62, 63, 71B and 72. 2) For other engines.		<p>Hand in injectors to authorized service dealer (or replace with adjusted injectors). Tightening torques: injectors 50 Nm (5 kpm/37 ft.lb.), pressure pipes 15–25 Nm (1.5–2.5 kpm/11.1–18.5 ft.lb.).</p> <p>N.B.: TAMD63/TAMD72 pressure pipes must not be bent. Replace if damaged.</p>	37
<p>*N.B.: Special recommendations apply for new or reconditioned engines. See instructions under heading "New engine with reverse gear" on page 23.</p>				
18.	Check/clean seawater filter. N.B.: The time must be judged by experience after running the engine for a while.			41
19.	Check batteries.		<p>Use protective goggles! Battery water approx. 10 mm (0.39") over cell plates.</p> <p>Warning! The batteries contain oxyhydrogen gas and extremely corrosive sulfuric acid. Naked flames/sparks close to batteries may cause an explosion.</p>	49
20.	Top up anti-corrosive agent in freshwater system.		<p>Add 1/2 liter (0.13 US gall.) of anti-corrosive agent (part. no. 1141526-2). N.B.: Only when glycol is not used in the cooling system.</p> 	14
21.	Clean cooling system. Replace coolant.		<p>Close sea cock and drain the water from the seawater and freshwater systems. Flush via holes for drain cocks and plugs until clean water runs out.</p>	21, 41

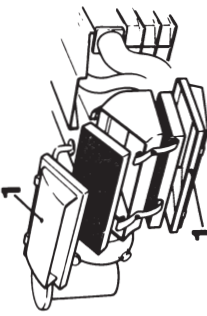
22.	Check/clean heat exchanger, aftercooler, and reverse gear oil cooler.	●		<p>Close sea cock and drain the water from the seawater and freshwater systems. See also instructions on pages 42 and 43.</p>	21, 42
23.	Check/replace pump impeller in seawater pump and any extra bilge pump.	●	<p>Close sea cock and drain the water from the seawater system. See also instructions on page 44.</p>		21, 44
24.	Check/replace zinc anode(s).	●	<p>Close sea cock before starting work. Drain the water from the seawater system. Replace the anode if more than 50% of it has been used. When fitting, ensure that there is good metallic contact between the anode and the material.</p>		21, 44
25.	Check for oil, fuel or water leaks.	●		<p>Check all connections and check for leaks. The rubber hoses should not be cracked or damaged, and all hose clips and connections should be tightened properly.</p>	-
26.	Check batteries' charge condition.	●		<p>Check the batteries' charge condition using a hydrometer. At ambient temp. of approx. +25°C (77°F), battery electrolyte density should be approx. 1.28 g/cm³ (1.24 g/cm³ with tropic acid). Charge the batteries if the density has dropped by 0.04 g/cm³.</p>	50
27.	Check/tension drive belt(s).	●	<p>Check for wear. Belts which work in pairs should both be replaced. Undo screws (A) before tensioning the belt(s). TAMD61, 62, 71, 72: It shall be possible to push the belts down approx. 10 mm (0.4") between the pulleys. TAMD63: Tension belt to 60 ±3 Nm (6 ±0.3 kpm/44 ±2 ft. lb.).</p>		29
28.	TAMD61, 62, 71, 72: Check function of stop solenoid.	●	<p>Get someone to help you connect the stop solenoid by turning the ignition key to the "S" position. Check at the same time that the stop position indicator pushes up the rubber seal on the top of the stop solenoid.</p>		50
29.	Check electrical lead connections.	●		<p>Clean the batteries' terminal posts and cable clips, lubricate them with Vaseline and tighten them. Also check that all other connections are properly tightened and have good contact. If necessary, spray these connections with a moisture-repellent spray.</p>	49

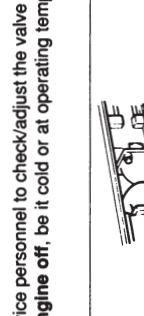
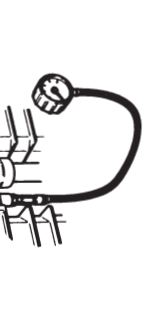
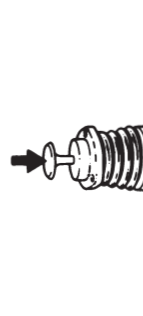
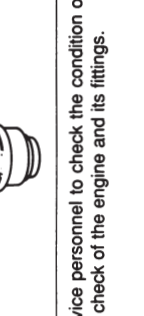
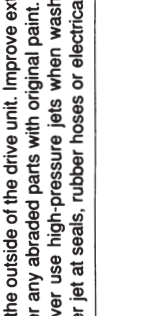
<p>30. TAMD61, 62, 71, 72: Replace air filter inserts.</p>		<p>Undo the clamps (x 6) for the covers (1). Remove the covers and replace the filter inserts. Check that the rubber hose against the turbocharger is undamaged and that the new filters are scrupulously clean. Fit the parts.</p>	<p>—</p>
<p>31. TAMD63: Clean air filter.</p>		<p>Wash the insert in pure diesel. Squeeze it out and place it in the filter housing. Fix the insert by pushing the O-ring down into the groove around the outer edge of the insert. N.B.: Replace the filter insert if it is damaged.</p>	<p>—</p>
<p>32. Get authorized personnel to check valve clearance.</p>		<p>Get authorized service personnel to check/adjust the valve clearance. This should be done with the engine off, be it cold or at operating temperature!</p>	<p>29</p>
<p>33. TAMD63, TAMD72: Get auth. personnel to check turbo charging pressure.</p>		<p>Get authorized service personnel to check the turbocharger's charging pressure.</p>	<p>—</p>
<p>34. TAMD63, 72: Get auth. personnel to check function of wastegate valve.</p>		<p>Get authorized service personnel to check the function of the wastegate valve.</p>	<p>—</p>
<p>35. Get auth. personnel to carry out a general check of engine and fittings.</p>		<p>Get authorized service personnel to check the condition of the turbocharger and carry out a general check of the engine and its fittings.</p>	<p>—</p>
<p>36. Check finish of engine and reverse gear.</p>		<p>If necessary, clean the outside of the drive unit. Improve external corrosion protection by painting over any abraded parts with original paint. Warning! Never use high-pressure jets when washing the engine. Never point the water jet at seats, rubber hoses or electrical components.</p>	<p>—</p>
<p>* N.B.: Special recommendations apply for new or reconditioned engines. See instructions under heading "New engine with reverse gear" on page 23.</p>			

THIS PAGE INTENTIONALLY LEFT BLANK

Technical Description

Engine

These engines are four-stroke, straight six marine diesel engines with overhead valves. They are fluid-cooled and equipped with turbochargers. The inlet air to the engine is cooled by a seawater-cooled charge air cooler (aftercooler) after compression in the turbo (TAMD71 and TAMD72 have double charge air coolers).

The engines have piston cooling (oil-cooled pistons). The lubrication system has a full flow oil filter, and the TAMD63 also has a partial flow (bypass) filter. This bypass filter is an accessory for other engines.

The cooling system is divided into a freshwater and a seawater system. The seawater cools the freshwater system via a heat exchanger (TAMD71 and TAMD72 have double heat exchangers).

Cylinder heads

The engines have two cylinder heads, each covering three cylinders, and are made of special-alloy cast iron. The cylinder head gaskets are made of solid sheet steel and have special rubber sealing rings inside for oil and coolant channels.

Valve system

The camshaft is journalled in seven bearings and is driven by the timing gears. The camshaft actuates the inlet and outlet valves in the cylinder heads via push rods and rockers.

In the TAMD71 and TAMD72, these valves have double valve springs.

Cylinder block

The cylinder block is made of special-alloy cast iron and cast in one piece. The cylinder liners are of the wet type, can be replaced, and have a flame barrier which considerably increases the service life of the cylinder head gaskets.

Crankshaft

The crankshaft is very strong and is journalled in seven main bearings. This shaft is statically and dynamically balanced and tempered according to a special method (nitrocarburization). This increases the fatigue strength and gives the bearing journals an extremely hard surface.

The journal at the front of the crankshaft has been ground to a polygonal shape. A polygon joint can withstand the stresses from the vibration damper (extra pulley or disengageable clutch) considerably better than a keyed joint.

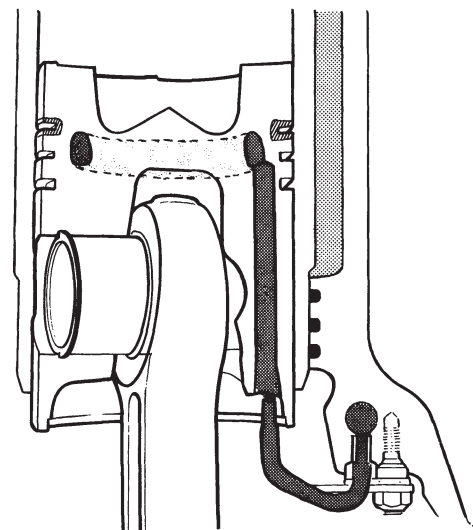

Piston cooling

Pistons

The pistons, which are made of an aluminum alloy, have two compression rings and one oil ring. The upper compression ring is coated with molybdenum (both compression rings in the TAMD71 and TAMD72), which helps reduce oil consumption and the risk of ring seizing.

The pistons are oil-cooled to reduce the risk of coking at high load. Piston cooling increases the service life of pistons, piston rings and cylinder liners and reduces oil consumption.

The engine's combustion chambers are located at the piston crowns.

Timing gears

The camshaft, oil pump, injection pump, circulation pump (TAMD61, 62 and TAMD71, 72), seawater pump and hydraulic pump (if fitted) are driven by the crankshaft via helical spur gears.

The gear wheels are of the helical spur type which operate very quietly.

Crankcase ventilation

The engines have ventilation devices to prevent overpressure and to run off diesel fumes, steam and other gaseous products of combustion. This is fitted on the right side of the engine and is connected to the air filter.

The gases from the crankcase pass through a disposable paper filter which separates off any oil mist before the gases are led away. Any oil is returned to the oil sump via a drainage hose. On the filter casing is also a relief valve which opens if the pressure in the crankcase becomes too high due to a blocked filter.

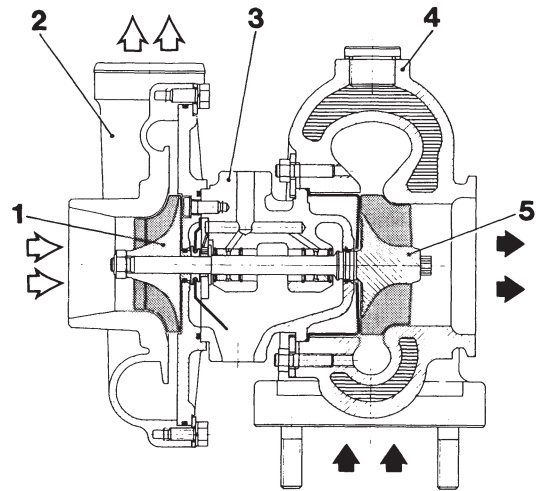

Turbocharger

- | | |
|-----------------------|--|
| 1. Impeller | 4. Turbine housing (freshwater-cooled) |
| 2. Compressor housing | 5. Turbine wheel and shaft |
| 3. Bearing housing | |

Air filter

The air filter prevents harmful particles from being sucked into the engine.

TAMD61, 62 and TAMD71, 72 have a dry filter with a filter element (disposable) of folded filter paper.

TAMD63, on the other hand, has a filter with a washable insert.

It is vital to replace/clean the filters in accordance with the maintenance schedule. A blocked filter results in smoky exhaust emissions and less engine output.

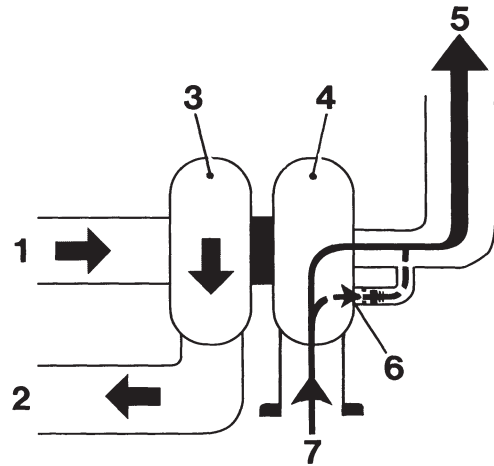

TAMD63P: Basic diagram of turbocharger with wastegate valve

- | | |
|-----------------------------|--|
| 1. Air from air filter | 6. Waste gas flow past turbine wheel via wastegate valve at high engine load |
| 2. Compressed air to engine | 7. Exhaust gases from engine |
| 3. Compressor housing | |
| 4. Turbine housing | |
| 5. Exhaust gas outlet | |

Turbocharger

The engines are fitted with a turbo charger which ensures a flow of air to the engine under pressure and thereby increases the amount of oxygen to the engine. The compressor, which is fitted to the exhaust manifold at the rear of the engine, is lubricated and cooled by the engine's lubricating oil.

TAMD63P and TAMD72A also have a wastegate valve (bypass valve). This is located in the turbine housing (TAMD63P) or between the exhaust manifold and the turbocharger (TAMD72A).

The wastegate valve means that the turbocharger is optimized for high charging pressure even at low engine speeds. The engine's low-speed torque is thereby improved greatly, while it also reacts more quickly to load changes.

At higher engine loads, the wastegate valve opens and forces some of the exhaust gases past the turbo and directly out into the exhaust pipe.

The turbocharger and wastegate valve are freshwater-cooled to reduce the radiant heat to the engine compartment.

Charge air cooler (aftercooler)

The inlet air passes through the charge air cooler(s) after compression in the turbocharger. The charge air cooler lowers the temperature of the air and thereby considerably improves the output ratio as the volume of the air is reduced. More air (oxygen) can therefore be forced into the engine's cylinders and burn more fuel per compression stroke; i.e. the output can be increased. Charge air cooling at the same time also helps reduce the thermal load on the engine.

See also under the heading "Heat exchanger and charge air cooler" on page 40.

Maintenance – Engine

Replacing filter for crankcase ventilation

1. Remove the old filter by unscrewing it counterclockwise.
2. Check the rubber gasket in the bracket, replace if necessary. Screw on the new filter by hand.

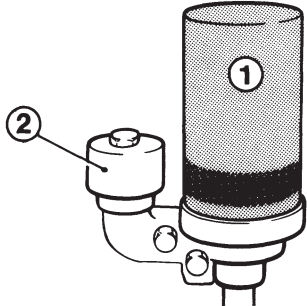

Filter for crankcase ventilation

1. Filter
2. Relief valve

Checking/tensioning drive belt(s)

Check the belt(s) for wear. Belts which work in pairs should both be replaced.

Undo screws (A) before tensioning the belt(s).

TAMD61, 62 and TAMD71, 72: It should be possible to press the belts down by approx. 10 mm (0.4") between the pulleys at the correct tension.

Tighten screws (A).

TAMD63: Place the stud of a torque wrench in the square hole in the tensioning pulley bracket. Tension belt to 60 ± 3 Nm (6 ± 0.3 kpm/ 44 ± 2 ft.lb.).

Tighten screws (A).

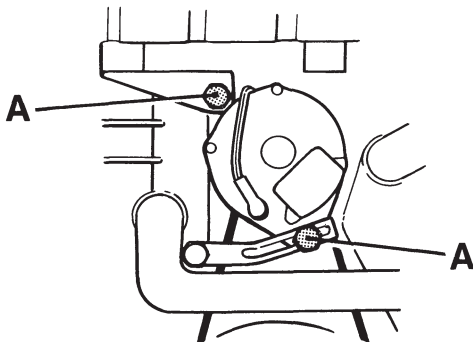

TAMD61, 62, TAMD71, 72: Tensioning drive belts

- A. Locking screws

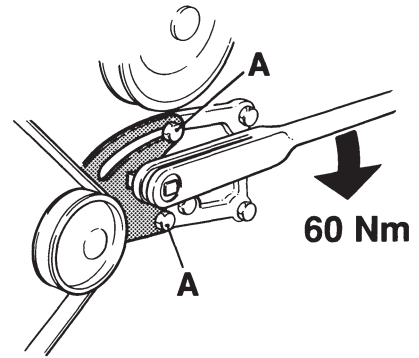

TAMD63: Tensioning drive belt

- A. Locking screws

Checking valve clearance

This check should be left to authorized service personnel.

N.B.: The clearance must never be checked with the engine running – the engine must be stopped, be it cold or at operating temperature.

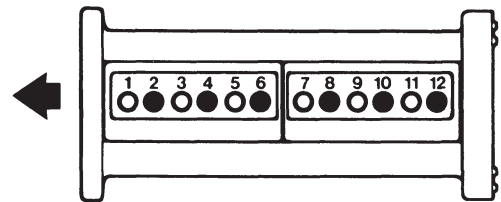

Valve location

- Inlet
- Outlet

Checking turbocharger

This check should be left to authorized service personnel.

However, a **cursory** check of the turbocharger may be carried out as follows:

1. Remove the air filter.
2.  **Warning!** Check that the turbocharger's impeller is stationary before checking.
3. Check whether the rotor shaft is running stiffly or whether the turbine wheel or impeller is catching on its housing. Turn the rotor, first with a light pressure and then with the application of a light axial load.

If the rotor is difficult to turn, the turbocharger must be replaced or reconditioned as soon as possible.

N.B.: If the turbo unit is to function satisfactorily, it is vital that the engine's lubrication system be maintained according to the maintenance schedule and that the correct type of lubricating oil be used in the engine.

Technical Description

Lubrication System

These engines have a forced lubrication system and piston cooling (see "Pistons" on page 27). The oil pump is of the gear-wheel type and is located at the front of the oil sump. This pump is driven by the engine's timing gears..

The oil pump sucks oil up from the oil sump and then forces it out into two main channels in the cylinder block (see basic diagram on next page). The oil passes through the lubricating oil filter and then on into the engine's oil channels for the forced lubrication of the engine, injection pump and turbocharger. The oil also passes through via the piston cooling valve. From here a small amount of oil is channeled off, which then passes through a bypass filter (in the TAMD63 – accessory in the other engines) before being returned to the oil sump. The rest of the oil continues through the oil cooler and out to the piston cooling jets.

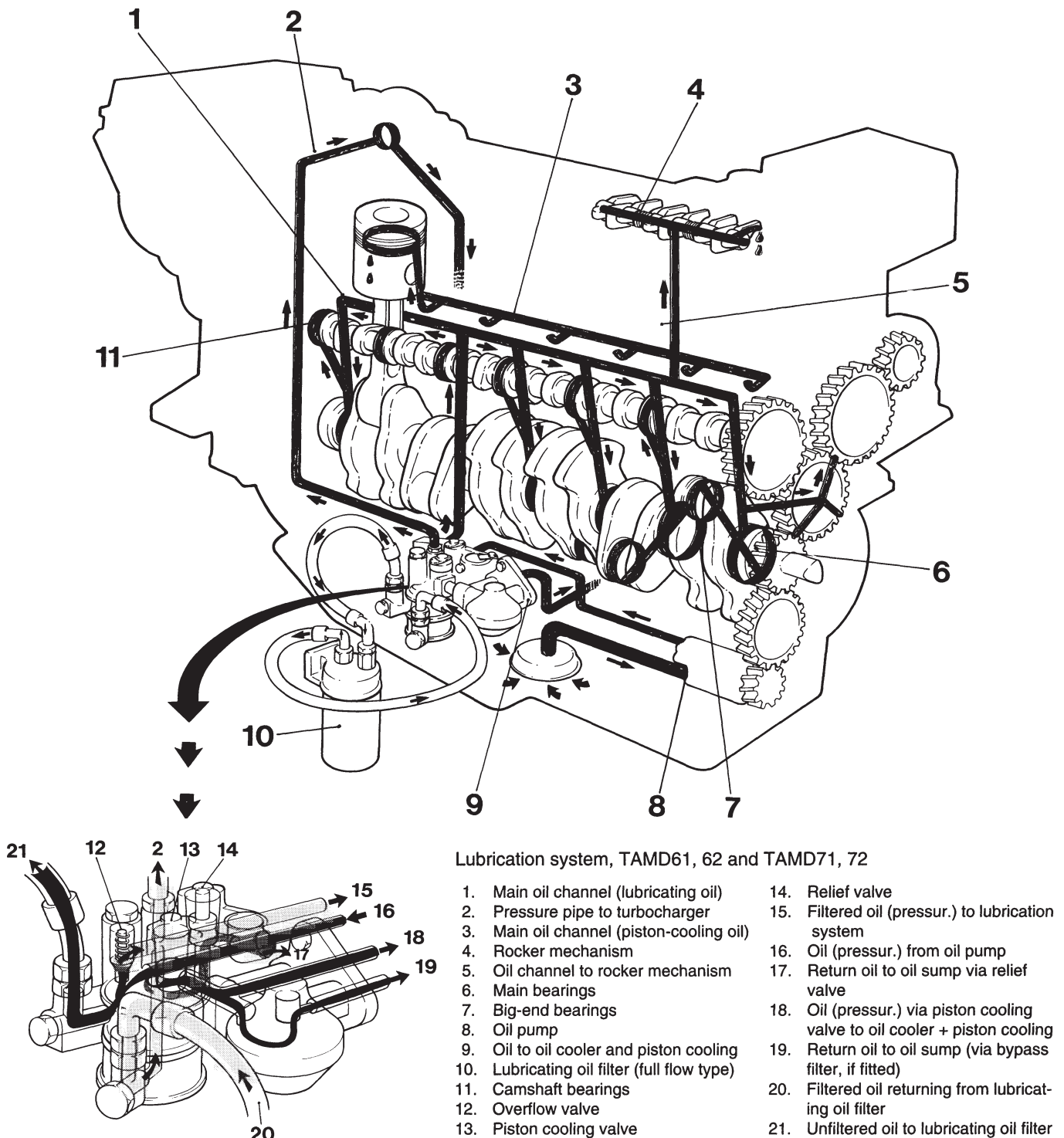

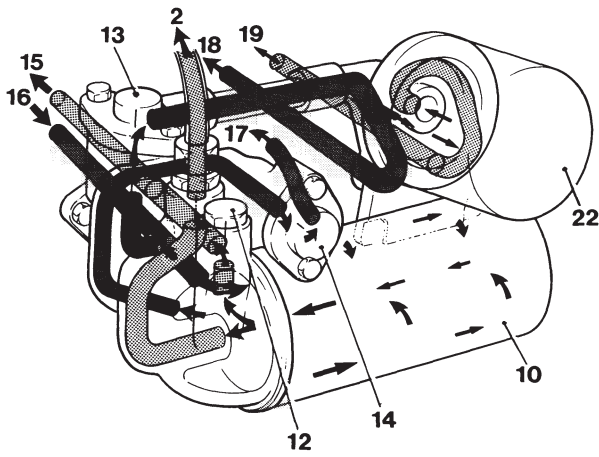

Lubrication system (partial diagram, filter housing), TAMD63

- | | |
|---|--|
| 2. Pressure pipe to turbocharger | 17. Return oil to oil sump via relief valve |
| 10. Lubricating oil filter | 18. Oil (pressur.) via piston cooling valve to oil cooler and piston cooling |
| 12. Overflow valve | 19. Return oil to oil sump (via bypass filter) |
| 13. Piston cooling valve | 22. Bypass filter |
| 14. Relief valve | |
| 15. Filtered oil (pressur.) to lubrication system | |
| 16. Oil (pressur.) from oil pump | |

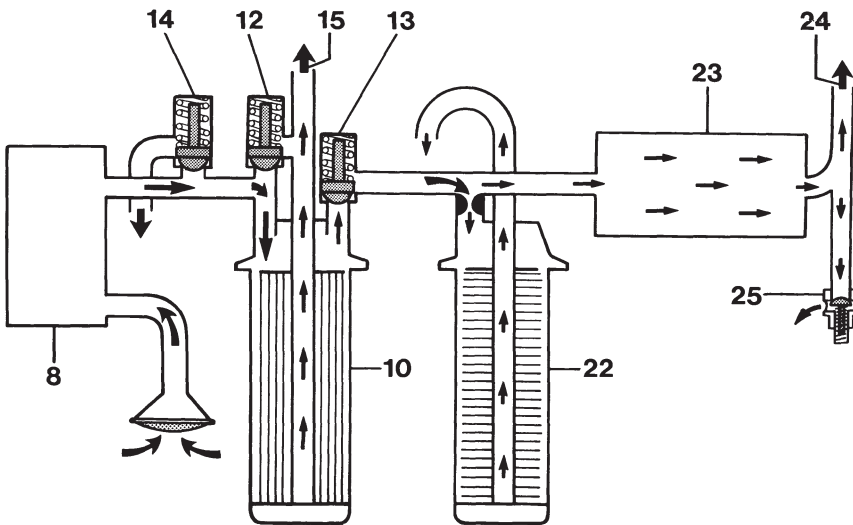

Basic diagram, lubrication system

- | |
|---|
| 8. Oil pump |
| 10. Lubricating oil filter |
| 12. Overflow valve |
| 13. Piston cooling valve |
| 14. Relief valve |
| 15. Filtered oil (pressur.) to lubrication system |
| 22. Bypass filter* |
| 23. Oil cooler |
| 24. Oil (pressur.) to piston cooling |
| 25. Bypass valve |

*N.B.: TAMD61, 62 and TAMD71,
72: Bypass filter is an accessory

Valves in lubrication system

The flow of oil in the engine is regulated by four spring-loaded valves. Of these, three are located in a bracket on the right of the engine and one is located at the bottom of the left hand side of the cylinder block.

- The relief valve (14) limits the pressure of the engine's lubricating oil. This valve opens if the pressure is too high and allows oil back to the oil sump, e.g. at high speeds or if the engine is cold and the lubricating oil is more viscous.
- The overflow valve (12) opens and allows oil past the lubricating oil filter if the resistance through the filter is too great. This ensures a continuous flow in the lubrication system in spite of a blocked filter. However, unfiltered oil passes out to the engine's points of lubrication in this case. Therefore, it is important that the filter is replaced according to the maintenance schedule.
- The piston cooling valve (13) regulates the flow of oil through the oil cooler and on to piston cooling.
- The bypass valve (25) permits increased oil flow through the oil cooler. This valve opens and allows excess oil not required for piston cooling back into the oil sump.

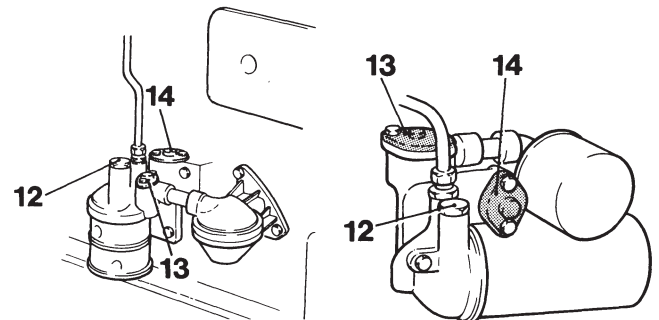

TAMD61, 62, 71, 72

TAMD63

Valves in lubrication system

- | | |
|--------------------------|------------------|
| 12. Overflow valve | 14. Relief valve |
| 13. Piston cooling valve | |

Maintenance – Lubrication System

Oil Change – Engine

The oil should be changed when the engine is hot.

⚠ Warning! Hot oil can cause burns.

Engines with oil scavenging pump (accessory): Remove the oil dipstick and connect the suction pipe to the dipstick tube. Start the pump and collect the oil in a vessel.

Alternatively, the oil can be drained after removing the oil sump drain plug.*

Fill oil through the filling neck on the front valve cover or the filler tube at the front of the engine (accessory in the TAMD61, 62 and TAMD71). For oil quality, see page 14. For oil quality and capacities, see “Technical Data” on page 62.

The oil level should be within the area marked on the dipstick. **The level must never be allowed to drop beneath the lower mark.**

The scavenging pump can also be used to add oil (the + and – cables are transposed on the electrical scavenging pump). See also the wiring diagram on pages 53 and 55.

N.B.: Collect up the old oil and hand it in at a collection site. Never contaminate the water with oil.

*N.B.: The TAMD63 has no drain plug.

Oil cooler

See the description in the “Cooling system” section on page 40 for information on the oil cooler.

Oil filter

The oil filter filters contaminants from the oil. The lubricating oil filter is of full flow type, which means that all the oil is filtered before it enters the lubrication system. The filter element is made of folded filter paper.

In the TAMD61, 62 and TAMD71*, 72, the filter is at the front of the engine. In the TAMD63, the filter is located in front of the starter motor on the right of the engine.

In all marine propulsion engines, the filter may alternatively (as an accessory) be located at the back of the engine's, left side.

The TAMD63 also has a bypass (partial flow) lubricating oil filter located above the lubricating oil filter. A bypass filter can be obtained as an accessory for other engines. This filter is located behind the lubricating oil filter at the front of the engine.

As a small amount of oil passes through the bypass filter, the flow rate is relatively low. The filter is therefore able to separate even very small particles from the oil. The filter element is made of folded filter paper.

*N.B.: In the TAMD71A classifiable auxiliary engine, the filter is located in front of the starter motor on the right of the engine.

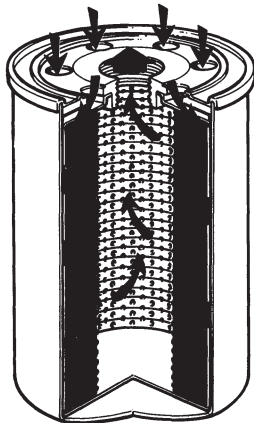

Lubricating oil filter

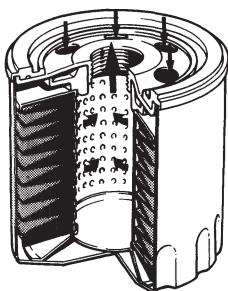

Bypass filter

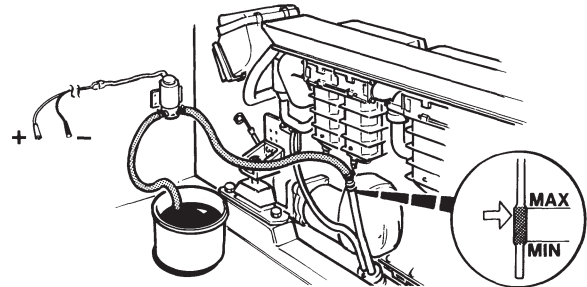

Draining oil from the engine

Replacing the lubricating oil/bypass filter

N.B.: Place a collecting vessel beneath the filter when removing the filter so that no oil is spilt.

1. Unscrew the oil filter (1) or bypass filter (2) using a special tool, then discard them.

⚠ Warning! Hot oil can cause burns.

2. Lightly oil the new filter's rubber gasket and check its mating surface with the bracket.

3. Screw on the new filter by hand until the gasket is in contact with the sealing surface. Then tighten the filter a further 3/4 turn (approx.).

4. Fill with oil, start the engine and check for leaks. Check the oil level after stopping the engine.

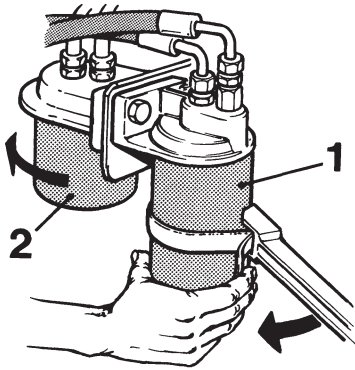

TAMD61, 62, 71, 72

1. Lubricating oil filter
2. Bypass filter (accessory)

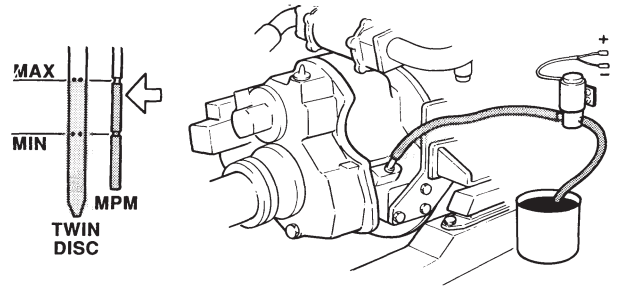

Draining oil from the reverse gear

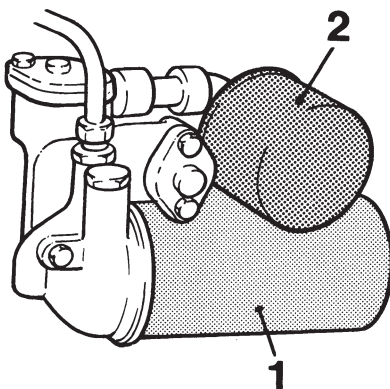

TAMD63

1. Lubricating oil filter
2. Bypass filter

Oil Change – Reverse Gear

Connect a hose from the oil scavenging pump to the oil dipstick tube on the reverse gear. Alternatively, drain the oil by removing the drain plug.

See also the instructions given under “Oil Change – Engine”.

1. Fill with oil through the filling neck on the top of the reverse gear. For oil quality and capacity, see “Technical Data” on pages 64–66.
2. Start the engine and run it until the reverse gear reaches **operating temperature**.
3. Check the oil level with the engine idling and with the control in neutral.

The oil level should reach the upper mark on the dipstick. Top up if required.

Cleaning the reverse gear’s oil screen

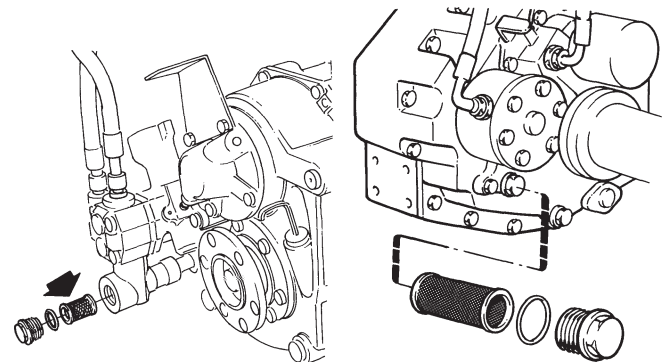

MPM IRM 220A

MPM IRM 301A

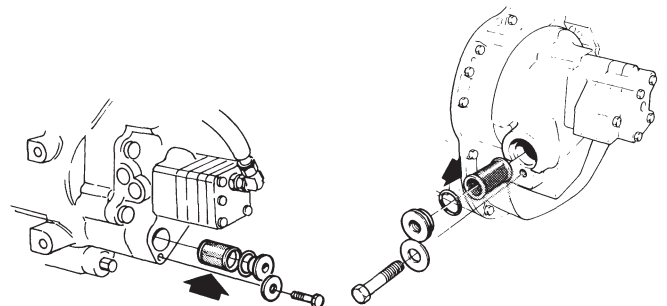

TD MG5061

TD MG507(A)-1

Technical Description

Fuel System

The fuel is drawn up by the feed pump from the fuel tank through the pre-filter(s) and is forced through the fine filters to the injection pump. Excess fuel escapes via the overflow valve back to the tank. This valve is located on the injection pump. This means that the return fuel flushes through (cools) the injection pump's fuel chamber. The temperature of the fuel is equalized by this (and will be the same in all the engine's cylinders) while bubbles of gas in the fuel are prevented.

The injection pump then forces the fuel under high pressure to the injectors, which atomize the fuel when it is sprayed into the engine's combustion chamber.

Return fuel from the injectors returns to the tank via the overflow valve.

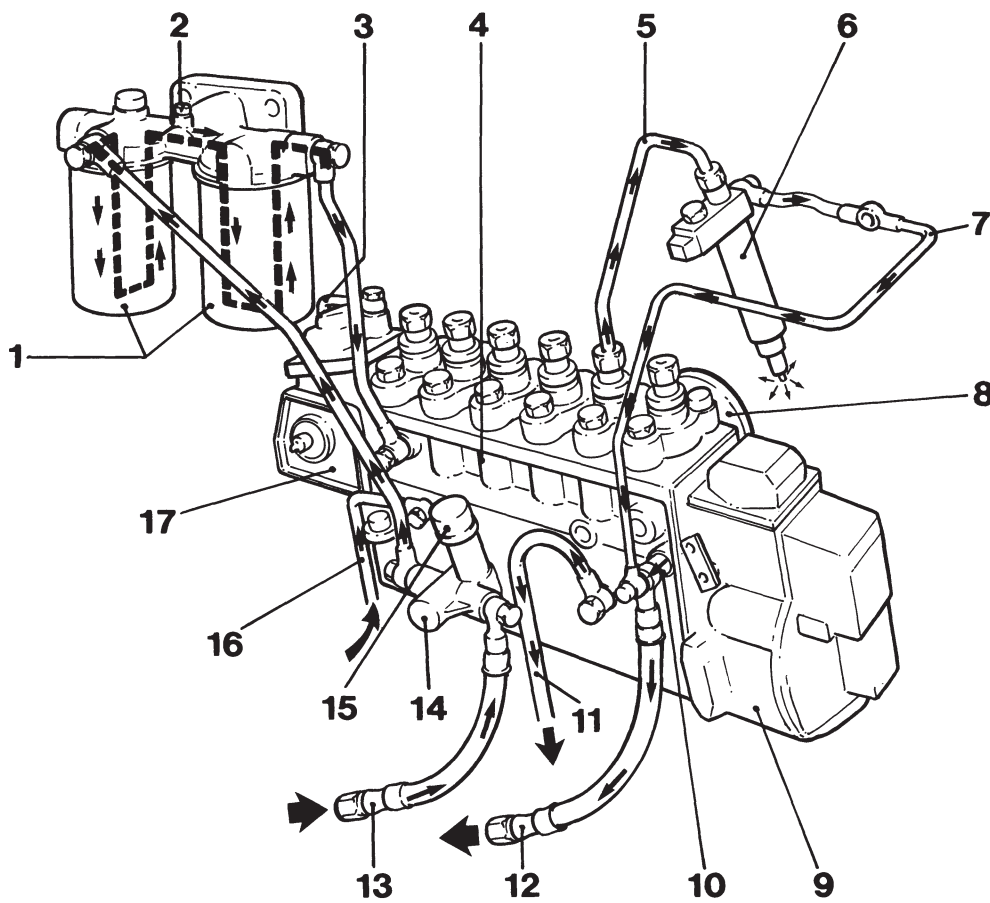

Fuel system

1. Fine fuel filters
2. Venting screw
3. Pressure pipe from inlet manifold (charging pressure)
4. Injection pump
5. Pressure pipe
6. Injector
7. Fuel leak-off line
8. Pressure equalizer
9. Centrifugal governor
10. Overflow valve
11. Return pipe, lubricating oil
12. Return pipe to fuel tank
13. Fuel line, intake
14. Feed pump
15. Hand pump
16. Lubricating oil pipe, inlet
17. Smoke limiter

TAMD63: Solenoid valve (fuel shut-off valve) for stopping engine

1. Solenoid valve

Connections in valve housing:

- T. Inlet from fuel tank
- P. Outlet to feed pump
- F. Inlet from fuel fine filters
- I. Outlet to injection pump

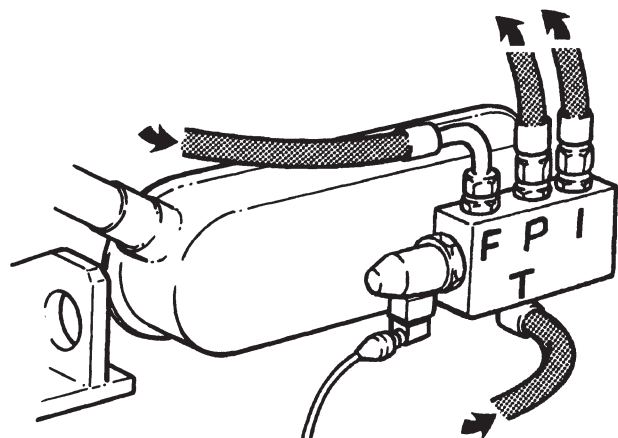

The fuel system has two fine fuel filters connected in parallel but with a common cover. These filters are disposable, and the filter insert is made of a spirally wound paper filter.

A single or double (connected in parallel) water-separating pre-filter is also available as an accessory. The inserts of the double pre-filter can, if necessary, be replaced while the engine is running.

It is important to replace the fuel filters according to the maintenance schedule. Blocked filters make the engine difficult to start and lead to reduced engine output.

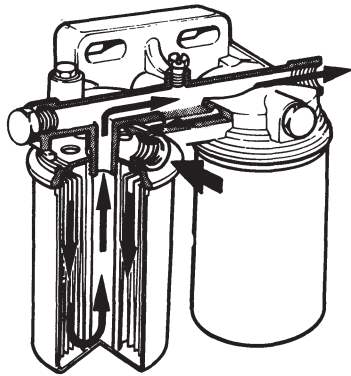

Fine fuel filters

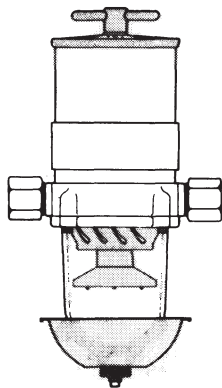

Extra pre-filter (single)

Injection pump

The injection pump is located on the left side of the engine and is driven by the timing gears. The pump, which is of piston type, has a centrifugal governor. This governor regulates the fuel feed to the engine so that the speed set by the driver using the control is achieved. It also limits the engine's max. speed if the load should suddenly drop.

Pressure-dependent full load stop (smoke limiter)

The injection pump has a pressure-dependent full load stop (smoke limiter) which is located at the front of the pump. Its job is to reduce sooty exhaust gases during hard acceleration from low speeds when the flow of exhaust gases through the turbocharger is too small to provide the full amount of air to the fuel injected by the injection pump. The smoke limiter is connected to the inlet manifold via a plastic tube.

Feed pump

If the injection pump is to work, it requires a supply of fuel under a certain pressure. This is dealt with by the feed pump, which is of piston type. This pump is located on the injection pump and is driven by the injection pump's camshaft.

The feed pressure is determined by an overflow valve located on the injection pump. This valve limits the feed pressure and ensures continuous venting of the fuel system.

When the engine is off, it is possible using the feed pump's hand pump to pump fuel to the filters and injection pump when venting the fuel system, e.g. after replacing the fuel filters.

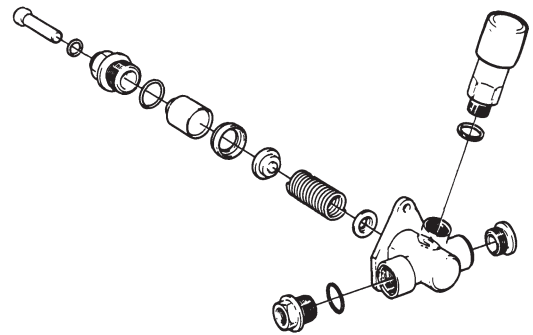

Feed pump

Injectors

The job of the injectors is to atomize and spray the fuel, metered precisely by the injection pump, into the engine's combustion chambers. This injection takes place under extremely high pressure so that atomization of the fuel (and, therefore, combustion) takes place as effectively as possible.

Each injector basically comprises a nozzle holder and a nozzle (jet). When the fuel pressure increases to a set value (opening pressure), the nozzle needle (7), which is pressed in its seat by the pressure spring (4), is raised, and atomized fuel is sprayed into the engine through carefully calibrated holes in the nozzle body. The tension of the pressure spring determines the opening pressure of the injector.

The injectors should be checked regularly by authorized personnel; see maintenance schedule. An incorrect opening pressure or faulty nozzle will result in smoky exhaust gases and lower engine output.

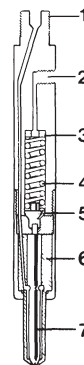

Injector

1. Pressure pipe connection
2. Connection for fuel leak-off pipe
3. Adjustment washers for setting the opening pressure
4. Thrust spring
5. Thrust pin
6. Nozzle casing
7. Nozzle needle

Maintenance – Fuel System

Checking/draining fuel pre-filters

Check the fuel filter and drain off any water and contaminants through the drain plug(s) (5).

The engine should be off and allowed to stand for a few hours before carrying out this check. Fit the plugs.

Fuel pre-filter – replacing the inserts





Double filter: As a rule, the filter inserts should be replaced when the vacuum gauge indicates a negative pressure of 6–10 in. Hg* (at idling speed) or 16–20 in. Hg (full speed, engine loaded). However, they should be replaced after every **500 hours of use**.

Close the fuel cocks at the tank before dismantling the single filter or replacing the inserts of the double filter with the engine off.

Double filter: If inserts are to be replaced when the engine is running, close the casing whose insert is to be replaced by turning the valve handle (1) to the horizontal position.

*N.B.: In. Hg = Inches of mercury.

Positions of the valve handle

-  **Up:** Normal operating position. Both filters are connected.
-  **To the right:** The left-hand filter insert may be replaced.
-  **To the left:** The right-hand filter insert may be replaced.
-  **Down:** Both filters are off.

1. Place a collecting vessel beneath the filter. Remove the cover (4) and lift out the insert by rotating it.
2. Drain off any water or impurities through the drain plug (5).
3. Fit a new filter insert and fill the casing with pure diesel oil. Fit the cover with a new gasket and tighten it by hand.

N.B.: Moisten the gasket with diesel oil before fitting it.
Cleanliness! No impurities may be allowed to enter the fuel system.

4. **Double filter:** Replace the second filter insert in the same manner.
5. Wipe any diesel off heat shield if fitted.
6. **Double filter:** Connect both filter casings (turn valve handle (1) up to the vertical position).
7. Open the fuel cocks and check for leaks.

Replacing the fine fuel filters

1. Clean the filter bracket carefully.
2. Unscrew the old fuel filters and discard them. If necessary, use a special tool to remove them.
3. Check that the new filters are absolutely clean and that the gaskets are undamaged. Lightly oil the gaskets.

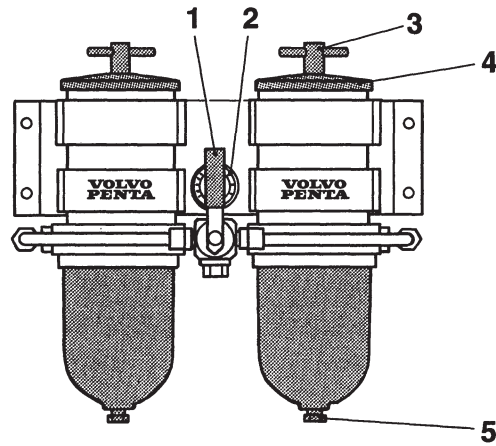

Double pre-filter

- | | |
|---|-------------------|
| 1. Valve handle (both filters connected in this position) | 3. Clamping screw |
| 2. Pressure gauge | 4. Cover |
| | 5. Drain plug |

The inserts may be replaced and the casings cleaned while the engine is running.

4. Screw on the new filters by hand until the gaskets come into contact with the bracket. Then tighten them a further **half turn** by hand.
5. Vent the fuel system as described on the next page. Start the engine and check the tightness around the filters.

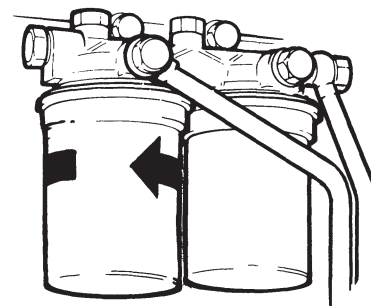

Replacing the fine fuel filters

Switchable fine fuel filters*

(Replacing while engine is running)

1. Place a collecting vessel beneath the fuel filters. Clean the filter bracket carefully.
2. Place valve lever (2) in the filter cover in its **right** end position.
3. Unscrew the **left** fuel filter and discard it. If necessary, use a special tool to remove it.

*Accessory for TAM71A auxiliary engine.

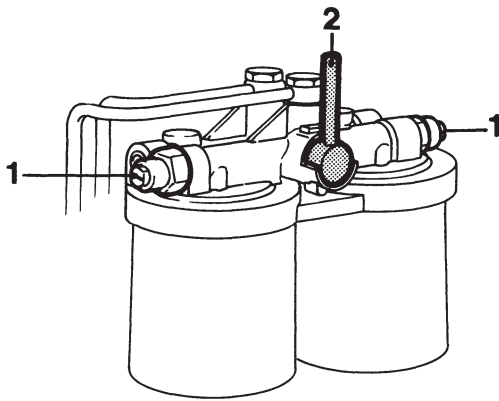

Replacing the switchable fine fuel filters

1. Vent screw for left and right filters
2. Valve knob (normal operating position)

4. Screw on the new filter by hand until the gasket comes into contact with the bracket. Then tighten it a further **half turn** by hand.
5. Open left vent screw (1) on the filter bracket. Move lever (2) vertically (operating position). Close the vent screw when air-free fuel flows out.
6. Place the lever in its **left** end position and replace the **right** fuel filter in the same way.

Venting the fuel system

The fuel system must be vented after the fuel filters have been replaced or after refilling the fuel tank after it has been run dry.

1. Place a collecting vessel beneath the fuel filters. Open vent screw (1) on the filter bracket.
2. Pump out fuel using the feed pump's hand pump (2) until air-free fuel flows out. Tighten the screw while fuel is flowing out.
3. Pump a further 10–20 strokes with the vent screw closed so that sufficient feed pressure is obtained. **Further venting is not normally required.**

If the injection pump needs to be vented anyway, undo the overflow valve (3) connection at the pump and continue to pump by hand until air-free fuel flows out. Tighten the connection while fuel is flowing out. Pump a further 10–20 strokes so that sufficient feed pressure is obtained.

4. Check for leaks.

Injectors – checking



N.B.: TAMD63 and TAMD72 have pretensioned pressure pipes. These pipes must under no circumstances be bent. Damaged pipes should be replaced.

1. Clean around the injectors.

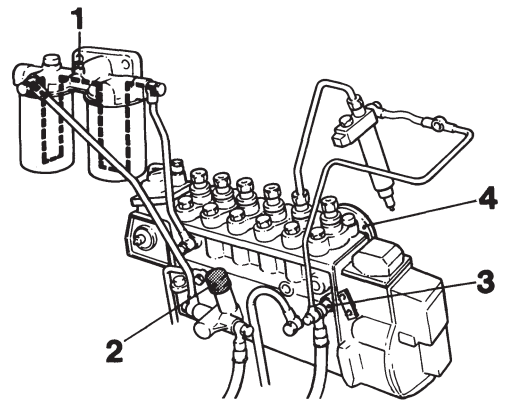

Venting the fuel system

1. Venting screw on filter bracket
2. Hand pump
3. Overflow valve
4. Pressure equalizer

2. Remove the pressure pipes and the fuel leak-off line. Remove the injector's mounting yoke.
3. Turn the injector carefully backwards and forwards using a wrench (size 15 mm) and pull it up at the same time.

N.B.: If the injector is stuck, you must use a special tool to remove it. The copper sleeve around the injector may otherwise be pulled out as well, with water in the engine as a consequence.

The coolant in the freshwater system can be drained as an extra safety measure before removing the injectors.

4. Hand in the injectors to an authorized service dealer for inspection.
5. Fit the injectors with a guard ring (1). Tightening torque 50 Nm (5 kpm/36 ft.lb.).
6. Fit the fuel leak-off line. Fit the pressure pipes. Check that these are not crooked, then tighten the nuts. Tightening torque 15–25 Nm (1.5–2.5 kpm/11–18 ft.lb.).
7. Fill the engine with coolant if this has been drained. Start the engine and check for leaks.

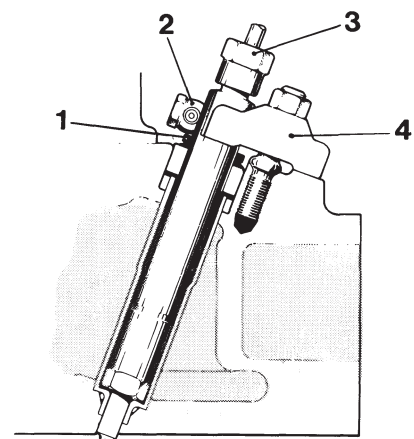

Injector

1. Guard ring (rubber)
2. Fuel leak-off line
3. Pressure pipe connection
4. Mounting yoke

Technical Description

Cooling System

These engines are fluid-cooled and have a closed cooling system which is divided into two circuits. In the inner circuit (the freshwater system), coolant is pumped around by a centrifugal-type coolant pump (circulation pump). In the TAMD63, this pump is driven by the vibration damper via a belt. In other engines, the coolant pump is gear-wheel driven via the timing gears.

From the coolant pump, the coolant is pumped out into a distribution channel in the cylinder block and conveyed around the cylinder liners and on up through the cylinder heads.

From each cylinder head and from the turbocharger's turbine housing, the coolant is fed back to the thermostat housing, where a thermostat regulates its temperature. Coolant from the engine's oil cooler is also fed to the thermostat housing.

While the coolant is cold, the thermostat shuts off the flow to the heat exchanger. The coolant then passes through a bypass line beneath the thermostat and directly back to the pump's suction side. When the coolant temperature has risen to a certain value, the thermostat opens and allows coolant to pass to the heat exchanger. The bypass line is closed off at the same time.

In the heat exchanger, heat from the coolant is transferred to the seawater before the coolant is sucked back into the coolant pump.

Large amounts of heat are also taken off by the lubricating oil, which channels off the heat to the freshwater system via the oil cooler. The lubricating oil is also used to dissipate heat from the pistons in the engine (see "Pistons" on page 27).

The cooling system may operate with a small amount of overpressure. The risk of boiling is thereby reduced if the temperature is high. If the pressure is higher than normal, a pressure valve in the filler cap opens.

The flow in the seawater system is maintained by a gear-wheel driven impeller (blade-type) pump which is located at the front of the engine. The seawater passes through the engine's heat exchanger(s)* and charge air cooler(s) and the reverse gear's oil cooler. A zinc anode is fitted in the reverse gear's oil cooler as protection against galvanic corrosion. The TAMD63 also has a zinc anode in the heat exchanger and the charge air cooler.

It is important to check the condition of the zinc anode(s) according to the maintenance schedule to prevent corrosion damage.

The engine may have a separate expansion tank as an accessory.

***N.B.:** In the TAMD63, the seawater passes the charge air cooler before being fed to the heat exchanger and the reverse gear's oil cooler.

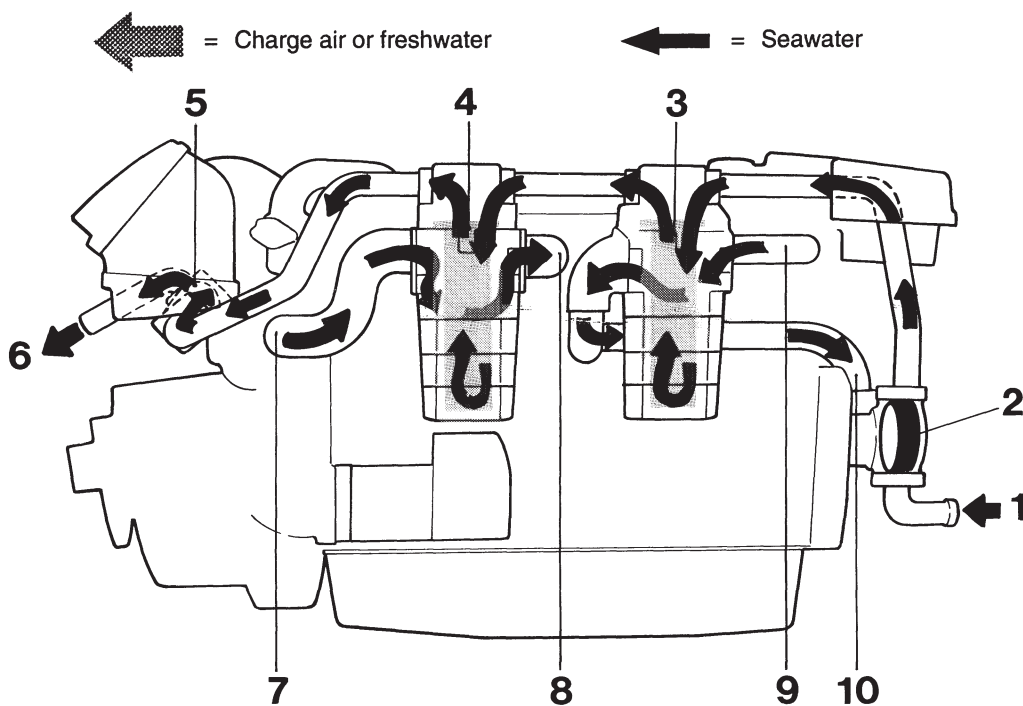

Flow through heat exchanger and charge air cooler in the TAMD61/62 and TAMD71/72*

- | | | |
|----------------------|-------------------------------------|--|
| 1. Seawater inlet | 5. Oil cooler, reverse gear | 8. Cooled charge air to engine inlet manifold |
| 2. Seawater pump | 6. Seawater outlet | 9. Freshwater from engine's thermostat housing |
| 3. Heat exchanger | 7. Charge air from the turbocharger | 10. Freshwater to coolant pump's suction side |
| 4. Charge air cooler | | |

***N.B.:** The TAMD71 and TAMD72 have double heat exchangers and charge air coolers connected in series.

← = Charge air or freshwater

← = Seawater

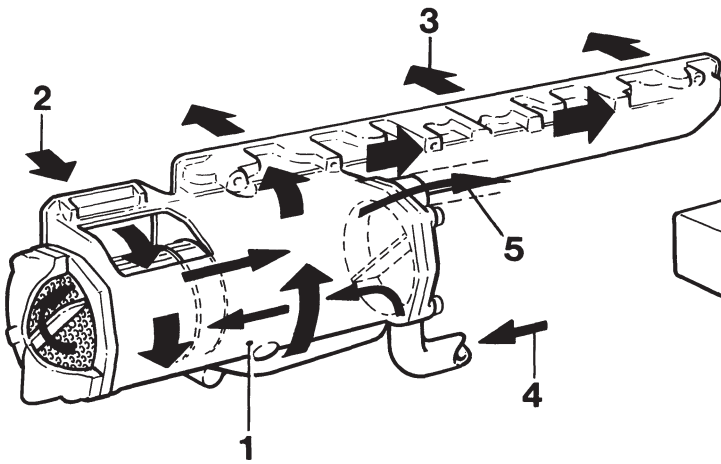

Flow through charge air cooler in the TAMD63

- | | |
|--|--|
| 1. Charge air cooler | 4. Seawater inlet (from seawater pump) |
| 2. Heated charge air from the turbocharger | 5. Seawater outlet (to heat exchanger) |
| 3. Cooled charge air to the engine's combustion chambers | |

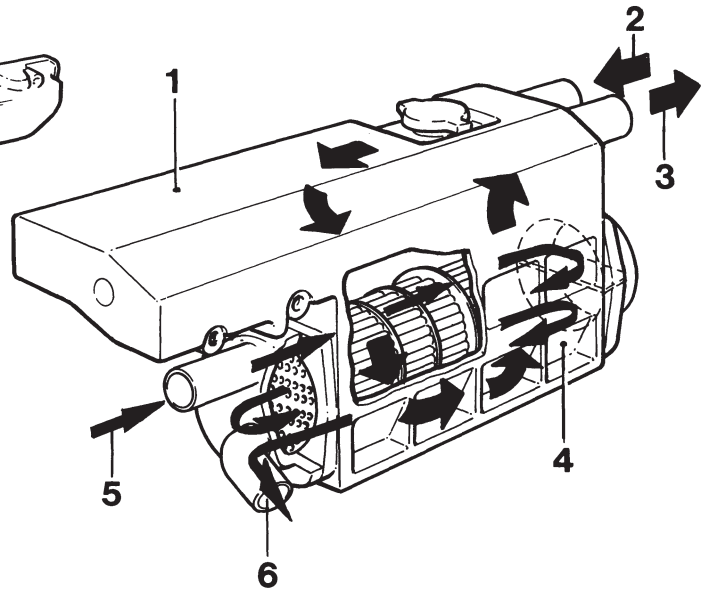

Flow through heat exchanger in the TAMD63

- | | |
|---|---|
| 1. Expansion tank | 4. Heat exchanger |
| 2. Hot coolant from the engine's thermostat housing | 5. Seawater inlet (from charge air cooler) |
| 3. Coolant to coolant pump's suction side | 6. Seawater outlet (to reverse gear's oil cooler) |

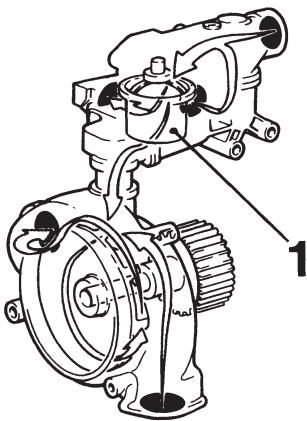

Coolant pump (circulation pump) and thermostat housing

1. Piston thermostat

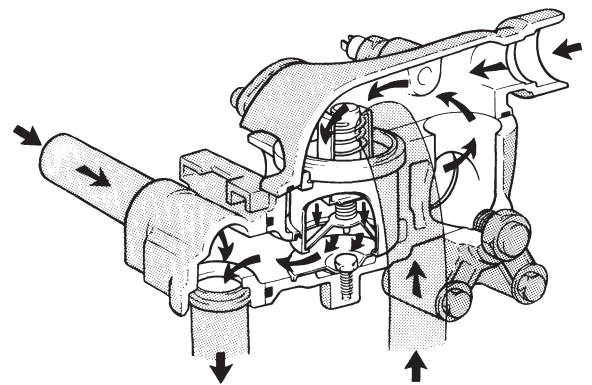

Thermostat function, cold engine

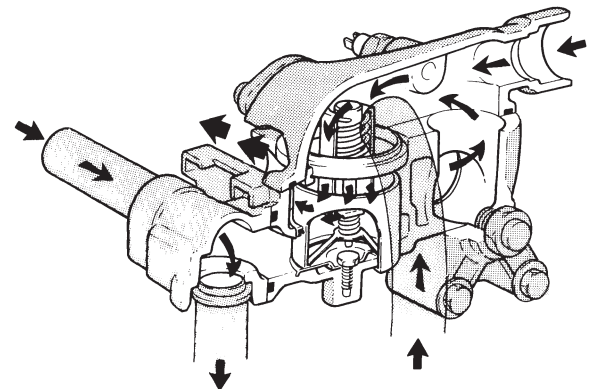

Thermostat function at operating temperature

Thermostat

The engines have a piston thermostat. The bulb of this thermostat is filled with wax. When the engine is cold, the thermostat keeps the route to the heat exchanger completely closed. The coolant is then fed directly back to the engine through a bypass line. After the engine has warmed up, the volume of the wax increases and the thermostat subsequently opens the route to the heat exchanger, while the bypass line is closed.

Seawater pump

The seawater pump is fitted to the transmission cover at the front of the engine. This pump is driven via the timing gears. The pump impeller is made of rubber and can be replaced.

N.B.: The impeller may be damaged if the pump is run dry.

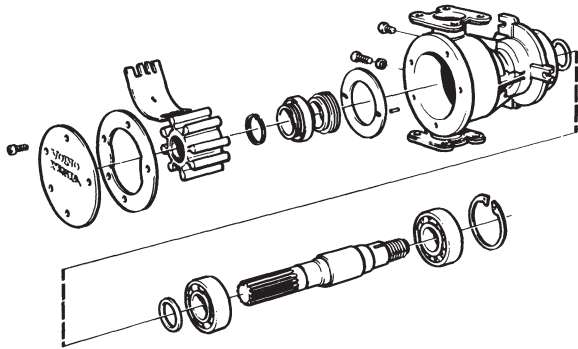

Seawater pump

Heat exchanger and charge air cooler

The TAMD61, TAMD62 and TAMD63 have a single heat exchanger and charge air cooler, while the TAMD71 and TAMD72 have double ones connected in series. The coolers are fitted on the right of the engine, the heat exchanger(s) foremost.

In the heat exchanger, heat is transferred from the engine's inner cooling circuit (the freshwater system) to its outer circuit (the seawater system). With the charge air cooler, heat is transferred from the charge air from the turbocharger to the seawater. See also under "Charge air cooler" on page 28.

The coolers comprise an aluminum housing with a tubular cooling insert.

The seawater passes through the pipes, while the freshwater (heat exchanger) or charge air (charge air cooler) passes between the pipes.

N.B.: On TAMD61, 62 and TAMD71, 72 the heat exchangers and charge air coolers are identical, so the cooling inserts, for example, are interchangeable.

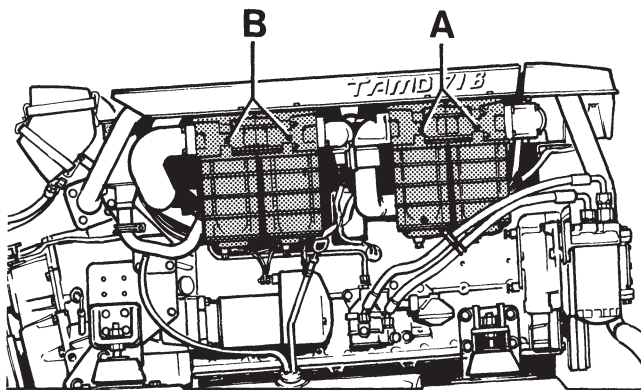

TAMD71, 72: Heat exchangers (A) and charge air coolers (B)

Oil cooler, engine

The lubricating oil transports heat from the engine's most heated parts and equalizes the temperature differences within the engine while the oil circulates. Heat is drawn off from the lubricating oil in the oil cooler. The temperature of the oil can therefore be kept lower at high load and speeds. In terms of wear, this is advantageous as the oil's lubricating properties are impaired if the oil temperature gets too high. Lubricating oils of lower quality are most sensitive to high temperatures.

The engine's oil cooler is on the left side, below the injection pump. The lubricating oil circulates inside the cooler assembly while the coolant passes between the cell plates. The cooler is connected to the freshwater system.

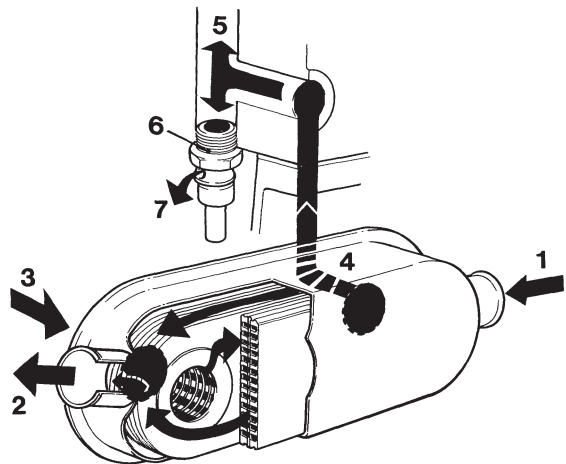

Lubricating oil cooler, engine

- | | |
|--------------------|--|
| 1. Inlet, coolant | 5. Oil for piston cooling |
| 2. Outlet, coolant | 6. Bypass valve |
| 3. Inlet, oil | 7. Excess oil being returned to the oil sump |
| 4. Outlet, oil | |

Oil cooler, reverse gear

The reverse gear's oil cooler is mounted on a bracket above the flywheel casing at the rear of the engine. The cooler is connected to the seawater system. The seawater passes through the pipes in the cooling insert and draws heat off from the oil which passes between the pipes.

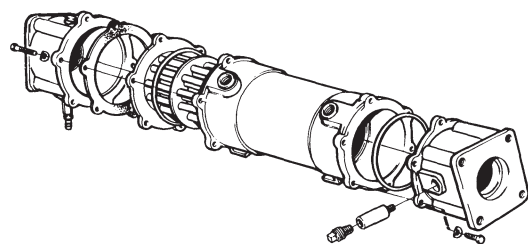

Oil cooler, reverse gear

Maintenance – Cooling System

Antifreeze and anti-corrosion, cleaning

⚠ Close sea cock before working on cooling system.

The coolant should be changed at least once a year to prevent cooling from becoming impaired due to deposits in the cooling system, and to avoid the risk of corrosion damage to the freshwater system since the anti-corrosive additives in the coolant are consumed over time.

The system should be flushed carefully with freshwater when changing the coolant. Flush until the water which runs out of the draining holes is clean.

N.B.: Some parts of the engine's cooling system are made of aluminum. Therefore, chemical agents must not be used for cleaning.

For how to drain the coolant, see "Draining coolant" on page 21. For antifreeze protection, see "Coolant" on page 14.

Filling with coolant

⚠ Warning! Open the filler cap/vent cock very carefully when the engine is hot. Steam or hot coolant may spray out.

Filling should be carried out with the engine stopped. Do not fill so quickly that air locks form in the system. Allow the air to flow out via the filling neck or vent cock.

When filling an empty system, or if the coolant level for some reason has dropped so low that it cannot be seen through the filling neck, open the vent cock at the turbocharger during filling. **The engine must not be started until the system has been vented and completely filled.**

If a heater system is connected to the engine's cooling system, the heat control valve should be opened and the unit vented during filling.

Fill with coolant* to approx. 5 cm (2") beneath the sealing surface of the filler cap or to between the MIN and MAX marks on the separate plastic expansion tank (accessory). For coolants, see "Coolant" on page 14. When topping up, use the same sort of mixture as is already in the cooling system.

Let the engine stand for approx. 1 hour after filling. Then top up the coolant if required, start the engine and warm it up. Check the coolant level.

Check that the cooling system is properly vented by **carefully opening the vent cock** after the engine has been started and has reached operating temperature. This will evacuate any air remaining in the system.

* **N.B.:** Cooling system capacity, approx.:

TAMD61 and TAMD62: 30 liters (6.6 imp. gals/7.9 US gals)
TAMD63: 27 liters (5.9 imp. gals/7.1 US gals)
TAMD71 and TAMD72: 35 liters (7.7 imp. gals/9.3 US gals)

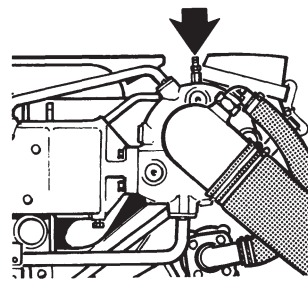

TAMD61, 62, TAMD71, 72

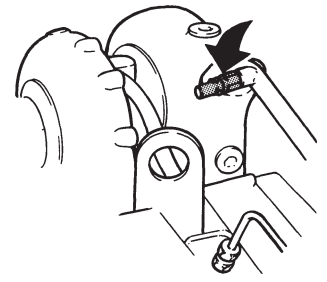

TAMD63

Venting cock in cooling system

Seawater filter, checking/cleaning

Volvo Penta offers two types of seawater filter. One is a smaller filter with a transparent perspex cover, and the other is larger and has a metal cover.

The filter cleaning intervals depend largely on the operating conditions and can be determined according to experience after operating your boat for a time. If necessary, clean the filter more often than specified in the maintenance schedule.

It is vital never to restrict the flow of seawater.

⚠ Close sea cock before working on cooling system.

1. Remove cover (1) and lift up the insert.
2. Clean the insert and housing (2).
3. Fit the parts as shown in the figures below. Check the gaskets or O-ring. Replace if required.
4. Open the sea cock and check for leaks.

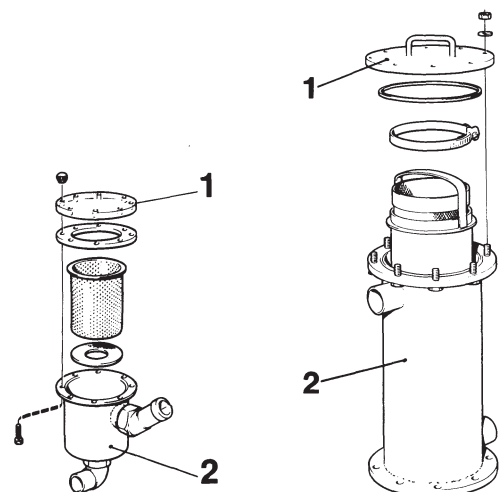

Seawater filter

Cleaning the heat exchanger/charge air cooler

TAMD61, TAMD62, TAMD71, TAMD72

⚠ Close the sea cock and drain the water from the seawater and freshwater systems before working on the cooling system.

1. Remove the cover plate over the heat exchanger and charge air cooler.
2. Remove the pipes between the seawater pump and the heat exchanger or between the charge air cooler and the reverse gear's oil cooler.
3. Remove the covers over the heat exchanger and the charge air cooler. Remove the connecting pipe(s) between the covers.
4. Remove the clamping rings beneath the housings. Remove the O-rings at the lower seal.
5. Lift the inserts. Flush and clean them internally and externally. Use suitable brushes. Clean the housings too.

N.B.: Ensure that no contaminants enter the engine's inlet manifold via the charge air cooler.

6. Fit the inserts in the housings. **N.B.:** Ensure that the inserts are fitted in the correct position. The locating lugs beneath the inserts' upper flange should face outwards (from the engine) and fit corresponding notches in the housings; see figure.
7. Place the sealing strips on the inserts' baffle plate and fit the covers together with the connecting pipe(s) between the covers. Use new sealing rings.

N.B.: The covers shall be fitted with the recess on the cover's flange facing forwards; see figure.

8. Fit the O-rings and clamping rings beneath the housings. Fit the coolant pipe between the seawater pump and the heat exchanger, or between the charge air cooler and the reverse gear's oil cooler. Use new sealing rings.

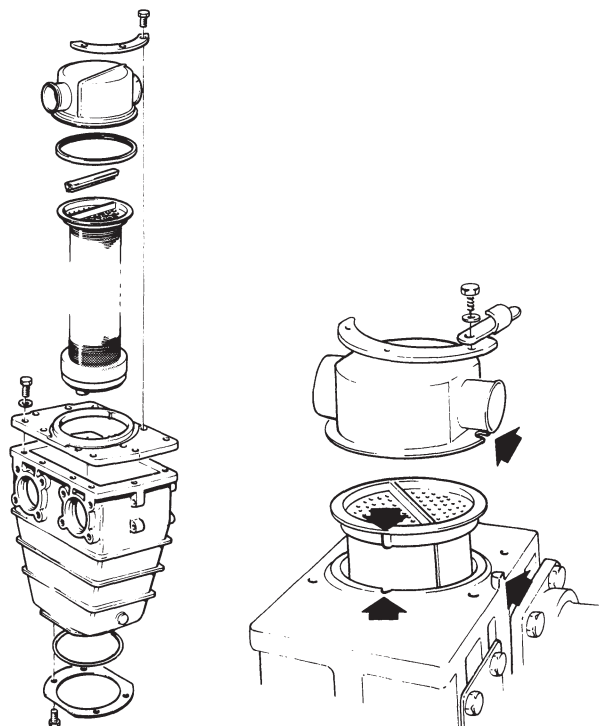

TAMD61, 62, TAMD71, 72: Heat exchanger/charge air cooler

Fit the cover plate over the heat exchanger and charge air cooler.

9. Fill the engine with coolant. Open the sea cock, start the engine and check for leaks.

TAMD63

⚠ Close the sea cock and drain the water from the seawater and freshwater systems before working on the cooling system.

1. Remove both battery leads.
2. Remove the oil pressure sender and oil pressure switch complete with bracket.

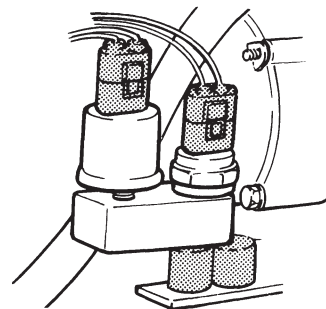

Bracket with oil pressure sender and switch

3. Remove the plastic pipe from the thermostat housing at the heat exchanger.

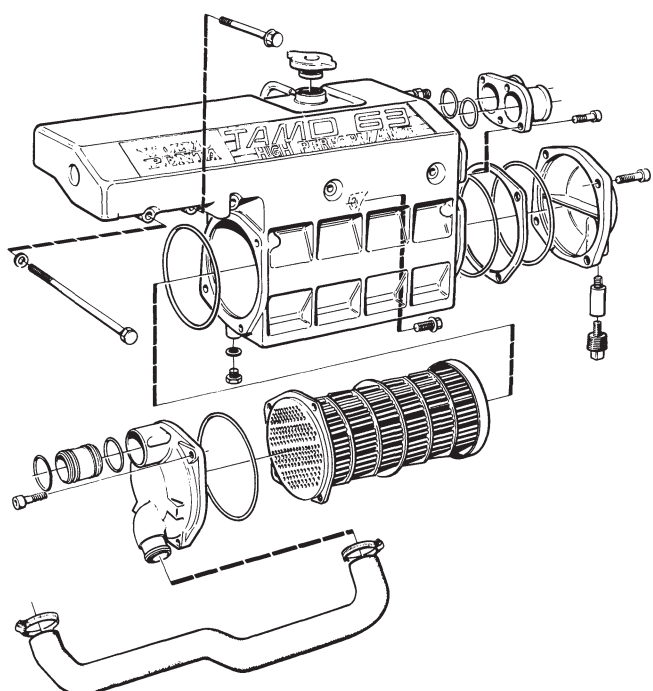

TAMD63: Heat exchanger and insert

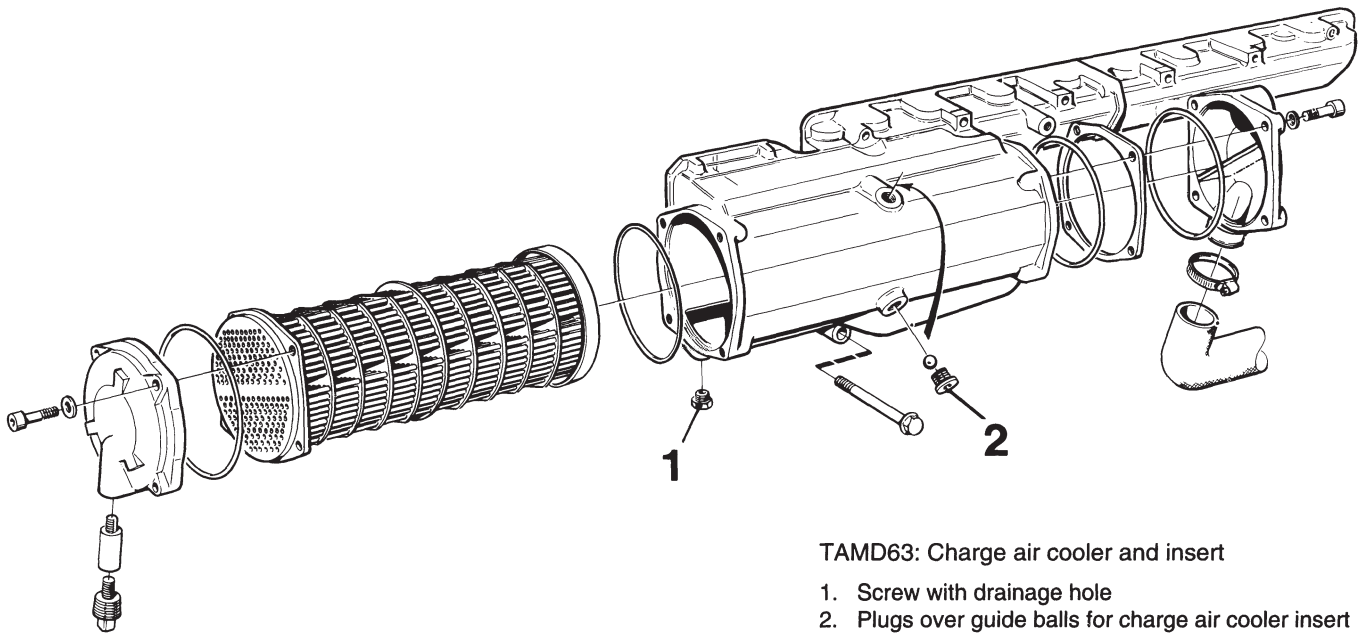

TAMD63: Charge air cooler and insert

1. Screw with drainage hole
2. Plugs over guide balls for charge air cooler insert

4. Remove the cooling water hoses to and from the heat exchanger/charge air cooler.
5. Remove the heat exchanger from the engine (6 screws).
6. Remove the end cover from the heat exchanger or charge air cooler (6 mm Allen screw). Remove the O-rings and intermediate rings.
7. Unscrew plugs (2) over the two guide balls for the charge air cooler's insert a few turns (10 mm Allen screw).
8. Push out the inserts.

N.B.: The inserts can only be pushed out backwards as they have a flange at the rear.

9. Flush and clean the inserts internally and externally. Use suitable brushes. Also clean the housings and covers.

N.B.: Ensure that no contaminants enter the engine's inlet manifold via the charge air cooler.

Check that the drainage hole in screw (1) at the back of the charge air cooler is not blocked.

10. Fit the inserts in the housings. Use new sealing rings.

N.B.: The intermediate rings should be fitted with the hole down. Inserts and intermediate rings can be fitted in only one position due to the distribution of holes.
11. Fit the end covers using new sealing rings. Tighten plugs (1) on the charge air cooler.
12. Fit the heat exchanger on the engine and tighten it.
13. Connect the cooling water hoses to the heat exchanger and charge air cooler. Tighten the hose clips.
14. Connect the plastic pipe from the thermostat housing to the heat exchanger.
15. Fit the oil pressure sender and oil pressure switch.
16. Connect the battery leads.
17. Fill the engine with coolant and vent the system as described on page 41.
18. Open the sea cock and start the engine. Check for leaks.

Cleaning oil cooler, reverse gear

⚠ Close sea cock before working on cooling system.

1. Open the drain cock on the oil cooler. Remove the cooling water pipes to and from the oil cooler.
2. Remove both end covers and push out the insert. (The insert can only be pulled out to the left as it has a flange on this side.)

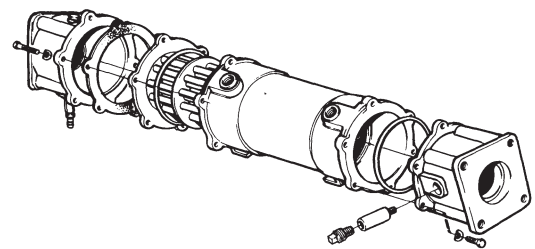

Oil cooler, reverse gear

3. Wash the insert in (e.g.) white spirit and blow it dry using compressed air (or let it stand and dry). Clean the tubes internally and the ends of the insert using suitable brushes. Clean the housing too.
4. Fit the parts in the opposite order. Use new sealing rings.
5. Close the drain cock and open the sea cock. Start the engine and check for leaks.

Checking/replacing zinc anode

⚠ Close sea cock before working on cooling system.

1. Open the drain cock on the reverse gear's oil cooler.
2. Unscrew the zinc anode on the oil cooler's right end cover.

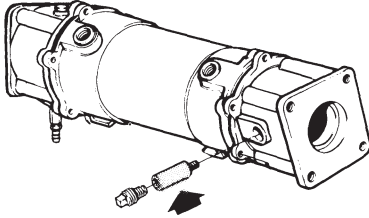

All engines: zinc anode in reverse gear's oil cooler

3. **TAMD63:** Unscrew the zinc anode in the heat exchanger's front end cover, or in the charge air cooler's rear end cover.

N.B.: The seawater in the heat exchanger or charge air cooler should be drained at the same time.



TAMD63: Zinc anode in heat exchanger's front end cover

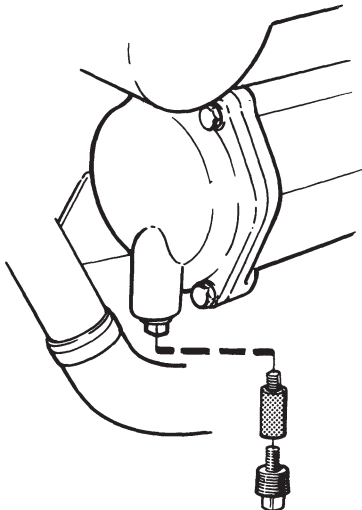

TAMD63: Zinc anode in charge air cooler's rear end cover

4. Replace the anode if more than 50% of it has been consumed. Otherwise clean the anode with an emery cloth to remove the oxide layer.

N.B.: Do not use a wire brush or other steel tools when cleaning, as these may damage the galvanic protection.

5. Fit the zinc anode(s). Ensure that there is good metallic contact between the anode and the material.
6. Close the drain cock. Open the sea cock before starting the engine. Check for leaks.

Replacing the seawater pump impeller

⚠ Close sea cock before working on cooling system.

1. Remove the pump's end cover. Pull and twist out the pump impeller using pliers.
2. Clean inside the housing. Lubricate the pump housing and the inside of the cover with a little lubricating grease.
3. Push in the new impeller with a rotating movement:
TAMD61, 62 and TAMD71, 72 – **counterclockwise**.
TAMD63 – **clockwise**.

4. Fit the cover together with a new gasket.

Ensure that you always keep a spare pump impeller and gasket on board.

5. Open the sea cock. Start the engine and check for leaks.

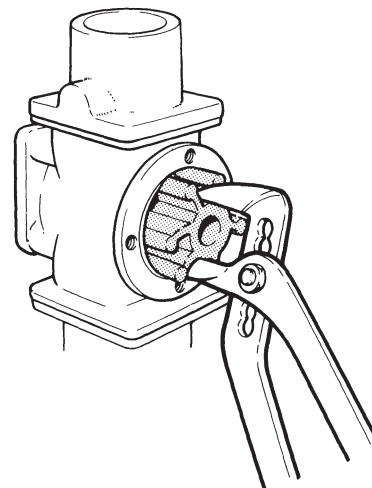

Removing the seawater pump impeller

Technical Description

Electrical System

These engines have an electrical system with a generous alternator capacity for a normal-sized boat. When extra power supply is required, we recommend that you fit an extra alternator or install a separate alternator unit.

These engines have a two-pole electrical system with an alternator. The system voltage is 12V or 24V. The TAMD61, TAMD62 and TAMD71 have an electrical starter element (air preheating) fitted as standard. In these engines, the starter element facilitates starting a cold engine and reduces exhaust smoke when starting in cold weather. In the TAMD63 and TAMD72, which both have higher compression (*inter alia*), different combustion chambers and a modified injection system mean that a starter element is not required.

The electrical system also includes switches for monitoring the engine's coolant temperature and oil pressure.

The electrical system is shown in two ways. The wiring diagrams (pages 51–57) shows the wiring, cable areas and cable colors. The positions of the respective parts in the engine/reverse gear are shown in the figures below or on the next page.

Positions of electrical components in engine and reverse gear: TAMD61, TAMD62 and TAMD71, TAMD72

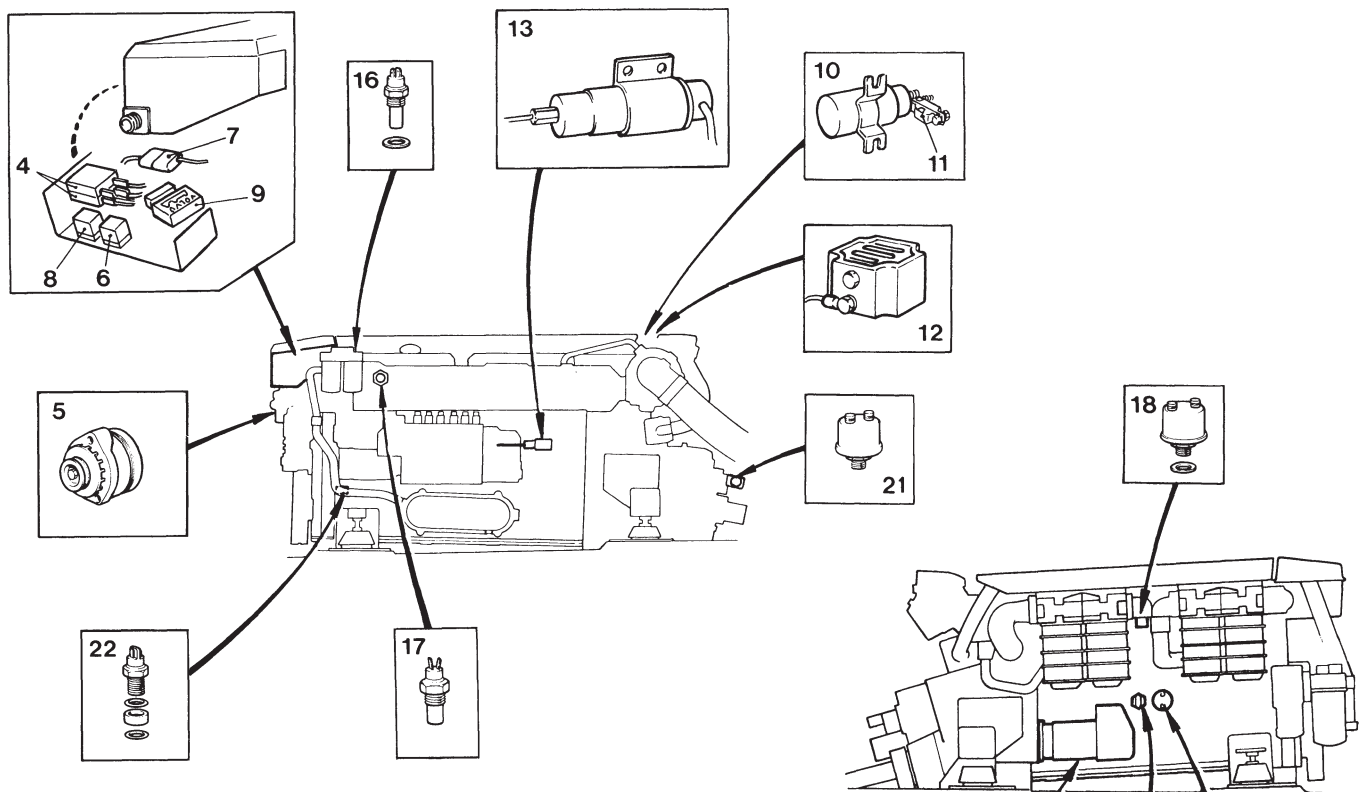

TAMD61, TAMD62 and TAMD71, TAMD72

N.B.: The components in the figures are numbered the same as in the engine's wiring diagram on page 53.

- | | |
|--------------------------------|---------------------------------------|
| 3. Starter motor | 12. Starter element* |
| 4. Semi-automatic fuses | 13. Stop solenoid |
| 5. Alternator | 16. Coolant temperature sender |
| 6. Start relay | 17. Coolant temperature switch |
| 7. Stop solenoid fuse | 18. Pressure sender, turbo pressure |
| 8. Stop relay | 19. Oil pressure sender, engine |
| 9. Time relay* | 20. Oil pressure switch, engine |
| 10. Relay for starter element* | 21. Oil pressure sender, reverse gear |
| 11. Fuse for starter element* | 22. Tachometer |

***N.B.:** The TAMD72 has neither a starter element nor a time relay

TAMD63

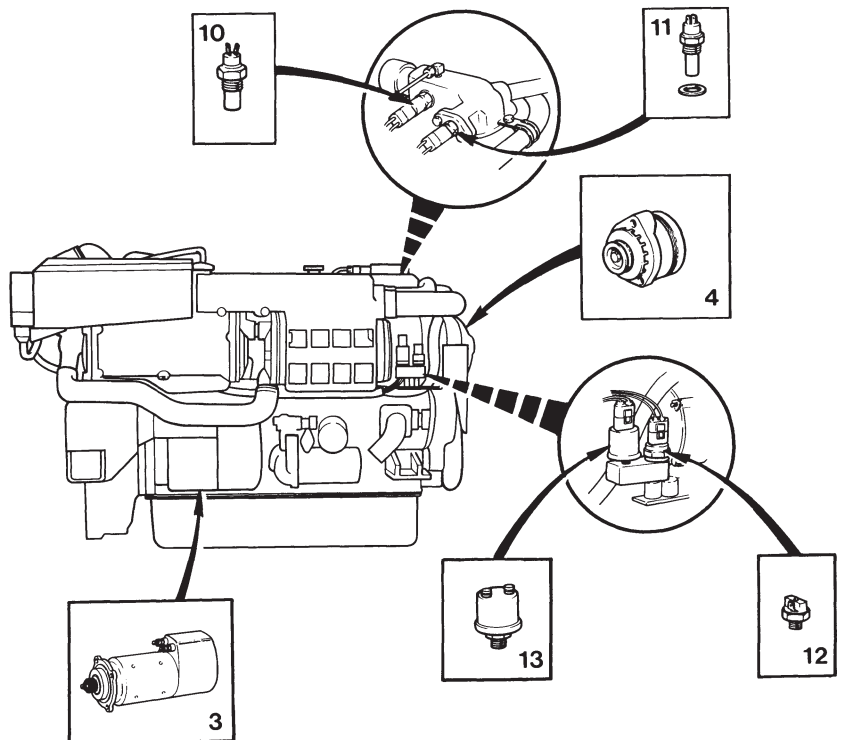
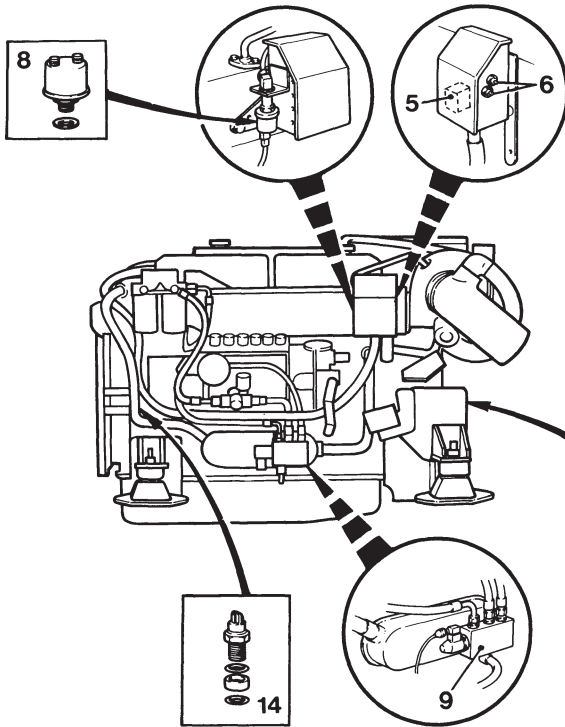

TAMD63

N.B.: The components in the figures are numbered the same as in the engine's wiring diagram on page 55.

- 3. Starter motor
- 4. Alternator
- 5. Start relay
- 6. Semi-automatic fuses
- 7. Oil pressure sender, reverse gear
- 8. Pressure sender, turbo pressure
- 9. Solenoid valve (fuel shut-off valve)
- 10. Coolant temperature switch
- 11. Coolant temperature sender
- 12. Oil pressure switch, engine
- 13. Oil pressure sender, engine
- 14. Rev. counter sender

Starter element

The starter element heats the inlet air to the engine. This element comprises three wire elements connected in series and mounted in a connecting pipe, and is located between the turbocharger and the engine's inlet manifold. The element is engaged automatically when the starter key is turned to/ passes the preheating position (II). This sends a voltage pulse to a time relay, which in turn controls engagement of the element via a control relay. The engagement time is approx. 50 s.

See wiring diagram on page 53.

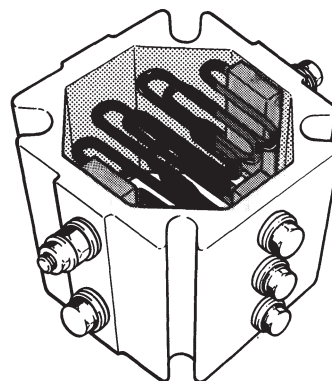

Starter element

Starter motor

The starter motor is mounted on the flywheel casing on the right of the engine.

When the starter motor is engaged, a drive on the starter motor's rotor shaft is moved in an axial direction so that it engages with a spur ring on the engine's flywheel. The drive's axial movement and the engagement of the starter motor are controlled by a control solenoid on the starter motor.

The starter motor's control solenoid is engaged in turn via the start relay* when the starter key is held in position III.

*Pos. 6 in the engine's wiring diagram on page 53, or pos. 5 in the diagram on page 55.

Alternator

The alternator, located at the front of the engine, is belt-driven.

The engine's standard alternator can be fitted with a charge distributor as an accessory. Two independent battery circuits can thereby be charged simultaneously. The charge distributor separates the two groups from one another so that the engine's storage batteries are kept fully charged even if the "accessory batteries" are weak or almost discharged.

N.B.: The charging voltage from the 28V/60A alternator is thermal compensated. The voltage increases at low temperatures and is reduced at elevated temperatures.

Voltage regulator with sensor system

The voltage regulator for the standard alternator (14V/60A, or 28V/40A* or 28V/60A) has a sensor system.

This sensor system compares the charging voltage between the alternator's B+ and B- connections with the charging voltage between the batteries' positive and negative poles. The voltage regulator then compensates any drop in voltage in the leads between the alternator and the batteries by increasing the charging voltage from the alternator, if necessary.

When supplied by Volvo Penta, the sensor system is not activated. However, it is likely that it was connected when the engine was installed.

***N.B.:** The 28V/40A alternator is for the TAMD63 engine.

Connecting the sensor system



Stop engine and shut off the power using the main switches before working on electrical system.

1. Release the yellow sensor cable from the B+ connection on the alternator.
2. Splice the cable (yellow, 1.5 mm²) and extend it to the batteries. Connect the cable to the batteries' positive (+) pole.

Charging control lamp (extra alternator)

A separate charging control lamp (3W) can be connected to the extra 28V/100A alternator.

A resistor "C", part No. 863400-8 (47Ω/25W), must also be connected as shown in a separate wiring diagram on page 51.

Stop solenoid

The stop solenoid is located on the left of the engine behind the injection pump (TAMD72), or on the exhaust manifold diagonally above the injection pump (TAMD61, TAMD62, TAMD71). This solenoid is engaged via the stop relay (pos. 8 in the engine wiring diagram) when the starter key is held in the stop position ("S").

See the wiring diagrams on pages 52–53.

When the solenoid is activated, the injection pump's control rod is moved into the zero delivery position and the engine stops as the flow of fuel into it ceases.

Solenoid valve

The TAMD63 has no stop solenoid. Instead, the engine is stopped via a solenoid valve (fuel shut-off valve) which is activated during stopping. When this happens, the valve changes the direction of the fuel flow to and from the feed pump so that a vacuum is created in the fuel chamber of the injection pump. This makes it impossible for the pump element to fill up and stop the engine.

This valve is located on a bracket beneath the injection pump.

Fuses

These engines have two semi-automatic fuses of approx. 8A. These fuses break the current in the event of overloading.

In the TAMD61, 62 and TAMD71, 72, the fuses are located in the front of the junction box on the left end of the expansion tank. In the junction box in these engines is also a safety fuse for the stop solenoid (16A at 12V, or 8A at 24V system voltage).

The TAMD63 has the junction box on the exhaust manifold at the rear left of the engine. The fuses are at the back of the box.

The electrical starter element* is also protected by a strip fuse (100A) between the element and the high power relay.

See instructions on page 49 for resetting/replacing fuses.

Make sure that you always have spare fuses on board.

***N.B.:** The TAMD63 and TAMD72 have no starter element.

Relays

The relays are located in the junction box. This is fitted to the expansion tank's left end (TAMD61, 62 and TAMD71, 72) or on the rear of the exhaust manifold on the left side of the engine (TAMD63).

The start and stop* functions are controlled via two change-over relays. These relays are identical and are therefore interchangeable if necessary.

The junction box in engines with starter elements** also contains a time relay which controls the starter element's rating (approx. 50 s) via a high power relay. This high power relay is located in front of the air filter adjacent to the starter element.

* Not TAMD63.

** TAMD63 and TAMD72 have no starter element.

General information

Electrolytic corrosion

Your boat and its engine/reverse gear have sacrificial anodes made of zinc as protection against galvanic corrosion. This protection may be rendered ineffective if there are any leakage currents from the electrical system due to faulty equipment or incorrectly connecting electrical components on the negative side (grounding, protector ground). The following should always be borne in mind:

The main switches should be mounted on both the positive (+) and the negative (-) battery leads. The main switches should break the current to all parts consuming electricity. Electrical leads should be fitted in such a manner that they are not exposed to moisture and there is no risk of them being exposed to bilgewater in the keelson.

If there are several battery circuits, there shall be separate switches for the extra equipment. There shall also be a main switch between the extra battery's positive (+) pole and the fuse panel for the boat's electrical equipment. The main switch for the extra battery circuit should break the current to all consumers of electricity connected to this circuit and be switched off when there is no requirement for extra current. The main switches to the engine should be switched off when the boat is not in use.

The propulsion package must not be electrically connected to other equipment such as the trim tab, steps, etc. Nor should it be used as ground for radio or navigational equipment or other electrical equipment where there are separate ground cables. All separate ground connections should be collected together to form a joint ground connection which is separate from the propulsion package.

If shore power is connected, protector ground should not be connected to the engine or to any other ground on the boat.

A transformer connected to shore power should be implemented in such a manner that protector ground on the inlet side (120/220V) and the minus connection on the outlet side (12/24V) are not connected.

 **Warning!** Electrolytic corrosion as a consequence of leakage currents may cause serious and expensive damage to your boat's equipment within a short time. Work on the boat's signal circuit should be carried out only by personnel trained in electrical technology or who have some expertise in the field. Installation or work on the shore power equipment **must only** be carried out by electricians authorised to work with high-voltage installations.

Important

 **Stop engine and break the current using the main switches before working on the electrical system.**

1. Main switches

Never break the circuit between the alternator and batteries while the engine is running. In other words, the main switches must never be disconnected before the engine has stopped. If the circuit is broken while the engine is running, the voltage regulator may be destroyed and the alternator seriously damaged.

Charging circuits must not be switched over while the engine is running, for the same reason. To simultaneously charge two independent battery circuits, fit a Volvo Penta charge distributor to the standard alternator (accessory).

2. Batteries

Never mix up the batteries' positive and negative poles when fitting them. Mixing them up may cause serious damage to the electrical equipment. See wiring diagram. The battery poles should always be well cleaned and the cable clips always tight and well greased so there is no break.

Avoid boosting the batteries. If boosting is required, both battery leads should first be removed.

N.B.: Follow relevant safety regulations when charging batteries. When charging, the cell plugs should be unscrewed, but they should remain in their holes. There should be good ventilation, particularly if the batteries are being charged in a closed area. Always break the charging circuit **before** removing the charging connectors.

 **Warning!** The battery area must never be exposed to naked flames or electrical sparks. Never smoke in the vicinity of the batteries. When charging, the batteries give off hydrogen gas which, together with air, forms oxyhydrogen gas. This gas is highly inflammable and extremely explosive.

Always wear protective goggles when charging or handling batteries.

The battery electrolyte contains highly corrosive sulfuric acid. In case of skin contact, wash with soap and copious amounts of water. If you get battery acid in your eyes, flush them immediately with copious amounts of water. Contact your doctor immediately.

3. See instructions on page 17 for how to start using auxiliary batteries.

4. Attaching extra equipment

All extra equipment should be connected to a separate junction box and fused. Extra outlets directly from the instrument panels should be avoided. However, the permitted **max. total** outlet is **5A** (for all instrument panels together).

Electric welding

Remove the positive and negative leads from the batteries. Then remove all leads to the alternator.

Always connect the weld clamp to the component to be welded and as close to the welding point as possible. The clamp should never be connected to the engine or in such a manner that the current is able to pass over any bearings.

 **When welding is complete:** Always connect the leads to the alternator **before** replacing the battery leads.

Maintenance – Electrical System

⚠ N.B.: Always stop the engine and break the current using the main switches before working on the electrical system.

Also read the section entitled “Electrical system – Important” on the previous page.

Resetting/replacing fuses

Ensure that you use the correct size of fuse when replacing safety fuses. Never fit a more powerful fuse.

Make sure that you always have spare fuses on board.

N.B.: If the same fuse often trips or needs to be replaced, consult authorized service personnel so that they can investigate the cause of the overload.

Semi-automatic fuses

The semi-automatic fuses are reset by pressing the respective fuse's button.

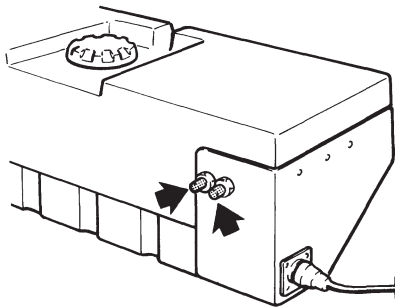

TAMD61, 62, TAMD71, 72

Terminal box with semi-automatic fuses

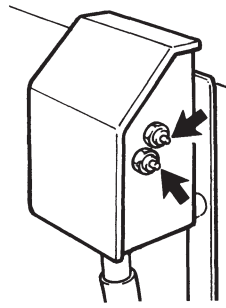

TAMD63

Stop solenoid fuse*

1. Stop the engine and break the current using the main switches.
2. Detach the terminal box and pull it out.
3. Dismantle the fuse holder and replace the fuse with a new one (16A for 12V, or 8A for 24V system voltage).
4. Fit the terminal box.

* **N.B.:** This applies to the TAMD61, 62 and TAMD71, 72.

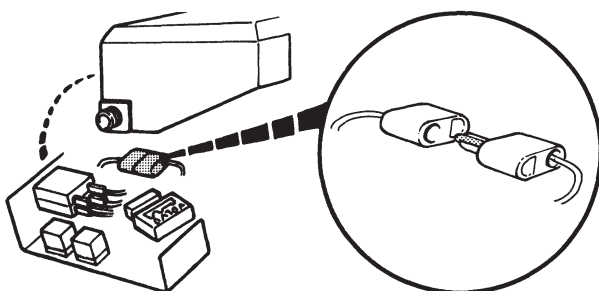

Stop solenoid fuse

Strip fuse for electrical starter element*

N.B.: This work should be left to authorized service personnel.

1. Stop the engine and break the circuit using the main switches.
2. Remove the cover plate over the high power relay.
3. Remove the old fuse (1) complete with holder (2).

N.B.: When removing and tightening the nuts** of the terminals on the starter element, these terminals must always be held tightly (see figure). Otherwise, the wire element may twist inside the starter element and cause a short circuit.

4. Fit the new fuse and support as shown in the figure. Fit the cover plate over the relay.

* **N.B.:** This applies to the TAMD61, 62 and TAMD71, 72.

** Tightening torque for terminal = 11–14 Nm (1.1–1.4 kpm/8–10 ft.lb.).

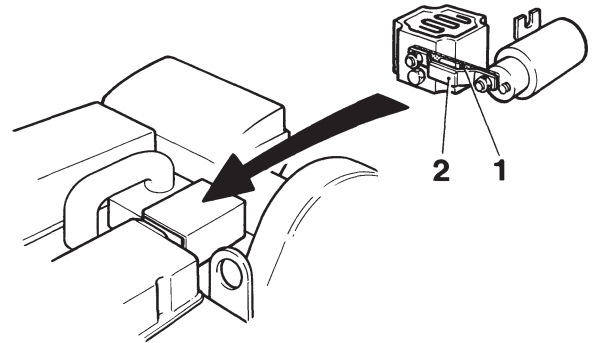

Strip fuse (1) with support (2) for electrical starter element

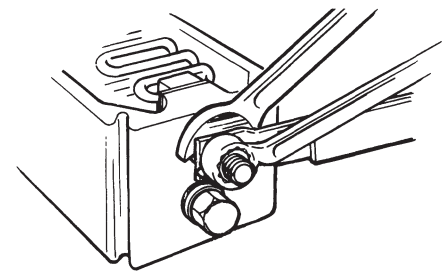

Removing/tightening nuts on starter element terminal

Checking batteries and electrical connections

⚠ Read the section entitled “Electrical system – Important” on page 48.

The service life of your batteries depends largely on how they are maintained. Keep the batteries dry and clean. Dirt on the batteries may cause tracking and discharge them, particularly in damp weather.

Clean the battery terminals and connections using suitable wire brushes. Poor contact may cause unnecessary voltage drops. Tighten the cable terminals well and spray the battery terminals and connections with anti-corrosive agent or coat them with Vaseline.

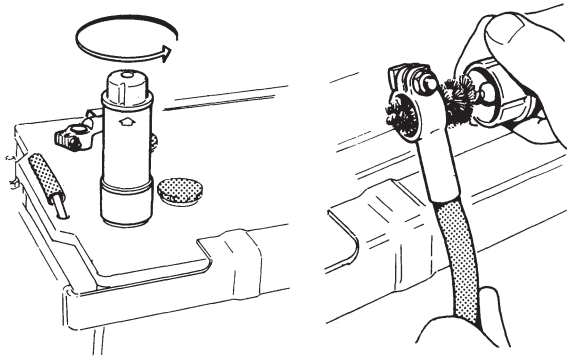

Cleaning the battery terminals

Check that the batteries are connected properly.

Also check that all other electrical connections are dry and free of oxidation and that there are no loose connections. If necessary, spray these connections with a water-repellent spray (Volvo Penta universal oil).

Charge condition

Check the batteries' charge condition using a hydrometer. The density of the battery electrolyte should be 1.28 g/cm³. * Charge the batteries if the density has dropped to 1.24 g/cm³* (approx. 75% charge).

N.B.: If an aerometer-type hydrometer (see figure) is used, the value read off applies at a temperature of approx. +25°C (77°F). At a different temperature, the value read off must be compensated as follows:

at -20°C (-4°F)	compensate by -0.03
at -5°C (23°F)	compensate by -0.02
at +10°C (50°F)	compensate by -0.01
at +40°C (104°F)	compensate by +0.01

Example: A value of 1.24 measured at -5°C (23°F) should be corrected to 1.22, which requires extra charging.

* **N.B.:** For batteries containing tropic acid, 1.24 g/cm³, or 1.20 g/cm³ applies.

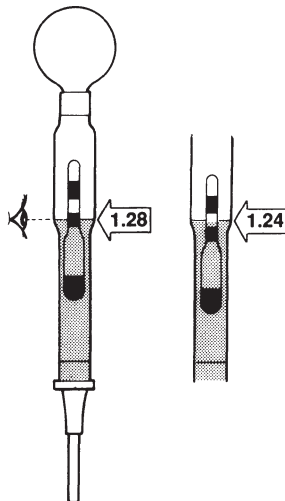

Aerometer-type hydrometer

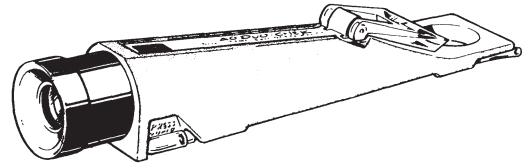

Optical-type hydrometer

N.B.: Optical-type hydrometers are temperature-equalized.

The various battery cells should display relatively even values. Uneven results may mean that the battery is more or less spent.

Stop solenoid

Setting the stop solenoid should be left to authorized service personnel. Incorrect setting may lead to the solenoid burning up.

However, a rough check may be carried out as follows:

1. Check that the stop solenoid and its operating lever are properly tight.
2. Get an assistant to engage the stop solenoid by turning the starter key to position "S".

Alternatively, the solenoid may be engaged directly via the connector at the solenoid. Dismantle the connector and connect pin 4 to the negative (-). Connect a control lamp between pins 3 and 4. Then switch on the power to pin 1 (+) via a fuse (16A for 12V, or 8A for 24V system voltage). The solenoid will be engaged and the control lamp will come on (shows that the solenoid has engaged the hold winding).

3. Check that the stop solenoid is engaged without seizing and that the stop position indicator on the top of the solenoid (rear in the TAM72) is pushing out the rubber diaphragm (see figure). This shows that the stop solenoid is in the bottom position.
4. Check that there is clearance of 1–2 mm (0.040–0.080") between the stop lever and the injection pump's end stop.

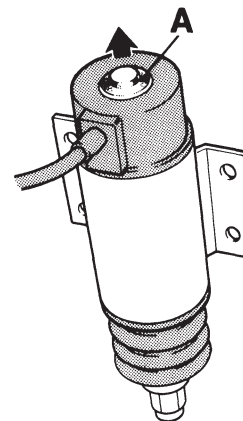

Stop solenoid

A. Stop position indication

Wiring Diagrams

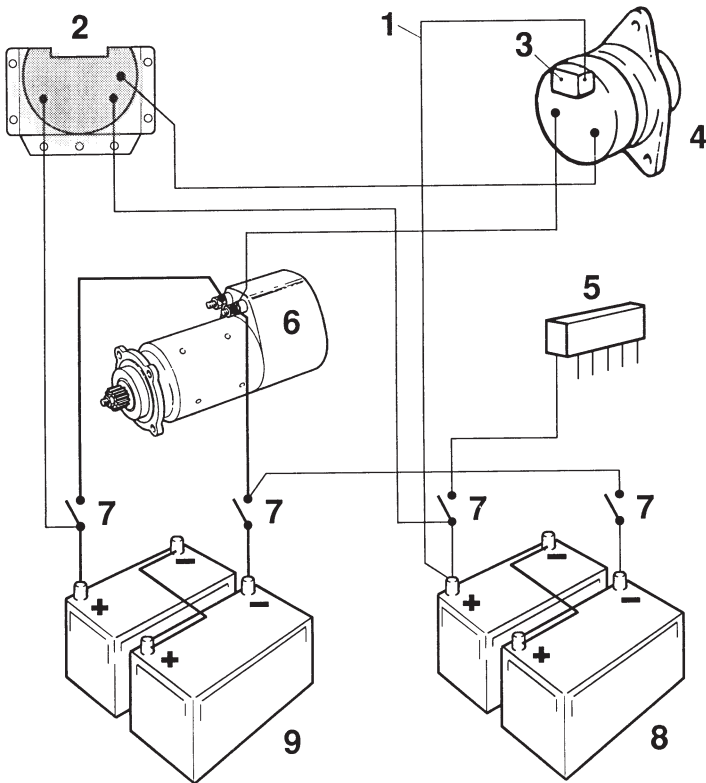

Connection of sensor system to standard alternator, basic diagram

- | | |
|--|--|
| 1. Sensor cable (yellow, 1.5 mm ²) | 6. Starter motor |
| 2. Charge distributor (accessory) | 7. Main switches |
| 3. Voltage regulator | 8. Accessory batteries (for accessories) |
| 4. Alternator | 9. Storage batteries (engine) |
| 5. Fuse panel (accessory) | |

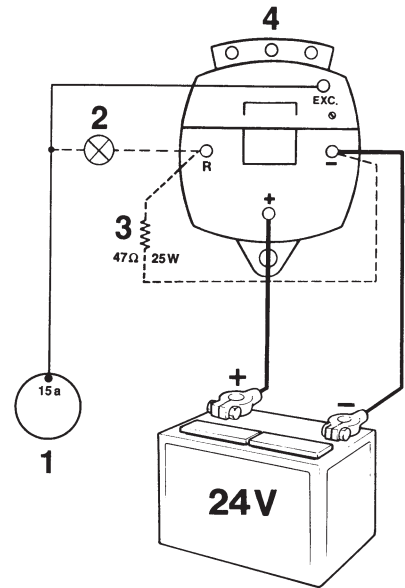

Connecting the charge control lamp

Extra alternator 28V/100A

1. Key switch
2. Charge control lamp
3. Resistor (47Ω/25W), part No. 863400-8
4. Alternator 28V/100A

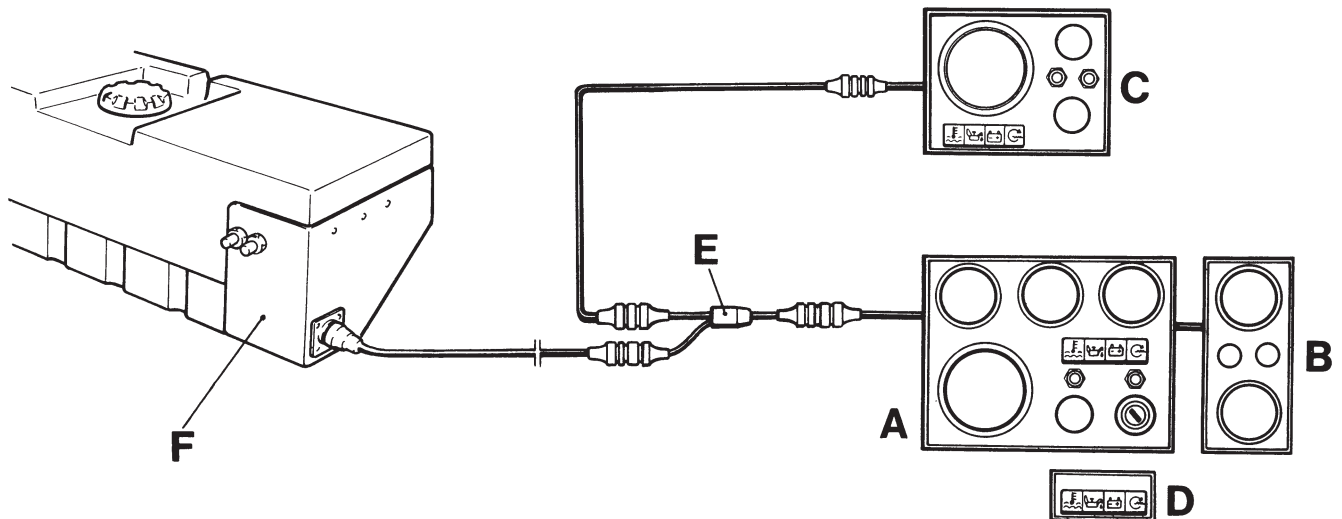

Block diagram

- | | |
|-------------------------|--|
| A. Main panel | D. Alarm panel (Used only when there is no main "A" panel) |
| B. Supplementary panel | E. Y-connector |
| C. Flying Bridge panel* | F. Junction box** with fuses |

* Main panel ("A") may also be fitted in the Flying Bridge panel. The senders for temperature and oil pressure must then be replaced.

**N.B.: The figure shows the TAMD61, 62 and TAMD71, 72

TAMD61, TAMD62, TAMD71, TAMD72

Cable areas in mm² are given after the color code in the wiring diagram.
 Cable areas are 1.0 mm² unless stated otherwise.

Flying Bridge panel

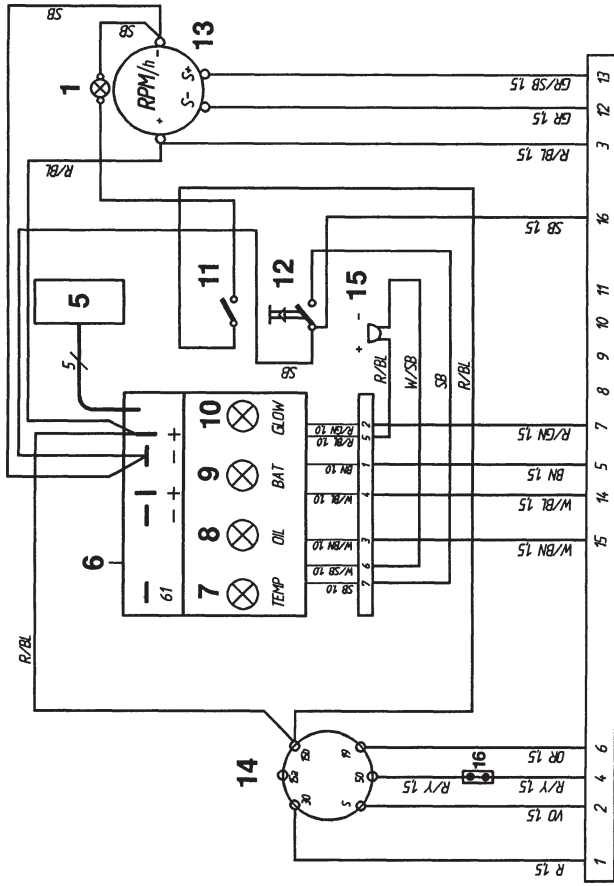

17

Instrument panels

1. Instrument lighting
2. Voltmeter
3. Oil pressure gauge
4. Coolant temperature gauge
5. Connector for extra warning display (accessory)
6. Electronic unit (alarm)
7. Warning light, coolant temperature
8. Warning light, oil pressure
9. Warning light, charging
10. Control lamp, preheater
11. Switch, instrument lighting
12. Switch, alarm test/acknowledgement
13. Tachometer with built-in hours run meter
14. Key switch
15. Alarm
16. Connector for neutral position switch, if fitted (accessory)
17. 2-pole connection (for supplementary panel, if fitted)

Spring loaded

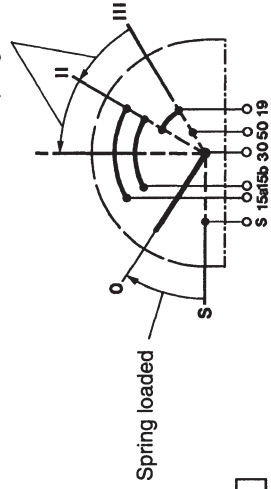

14

Instrument panel (main panel)

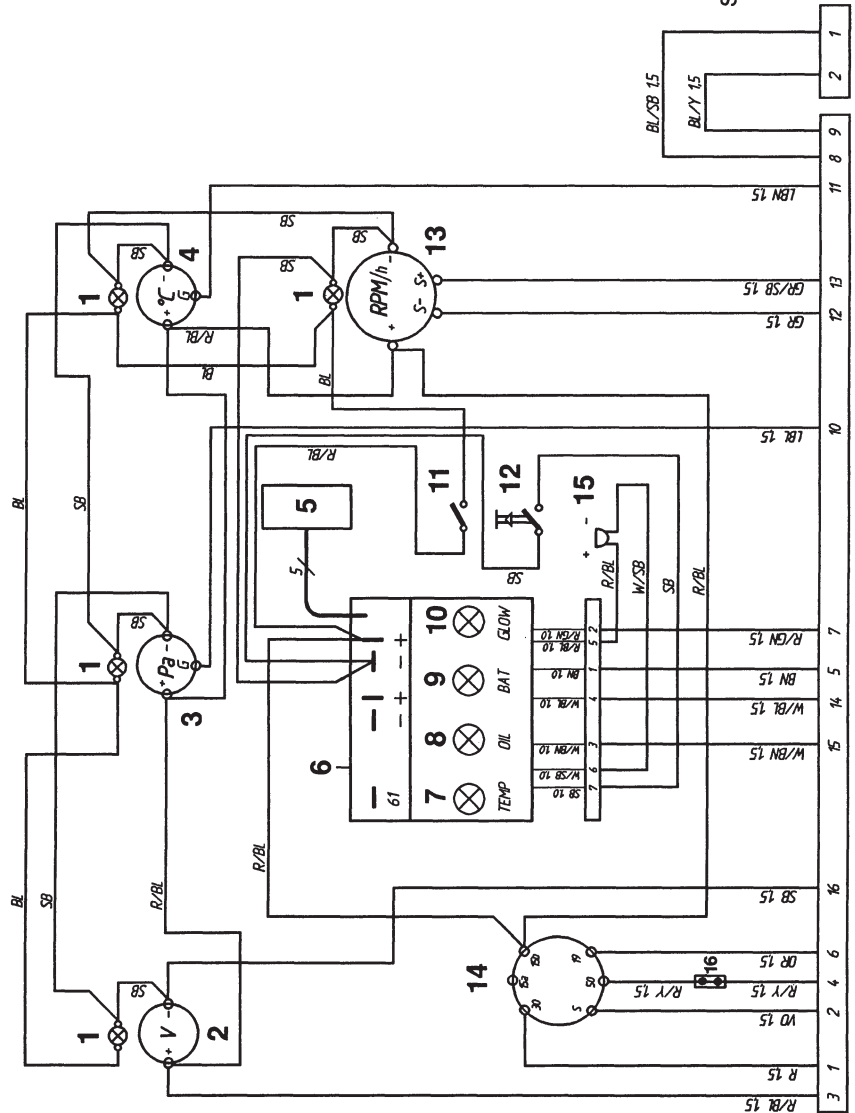

17

18

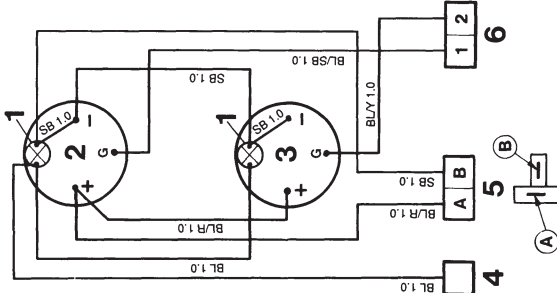

Supplementary panel

- Instrument lighting
- Oil pressure gauge, reverse gear
- Turbo charging pressure gauge
- Connection to instr. light. on main panel
- Connection to printed circuit card on main panel
- Connection to connector (18) on main panel

Cable colors

BL = Blue	R = Red
LBL = Light blue	SB = Black
BN = Brown	TRANSP. = Transparent (colorless)
LBN = Light brown	VO = Violet
GN = Green	W = White
GR = Gray	Y = Yellow
OR = Orange	
PU = Purple	

Ratio mm²/AWG*

* American Wiring Gauge

mm ²	1.0	1.5	2.5	10	16
AWG	16 (17)	15 (16)	13	7	5

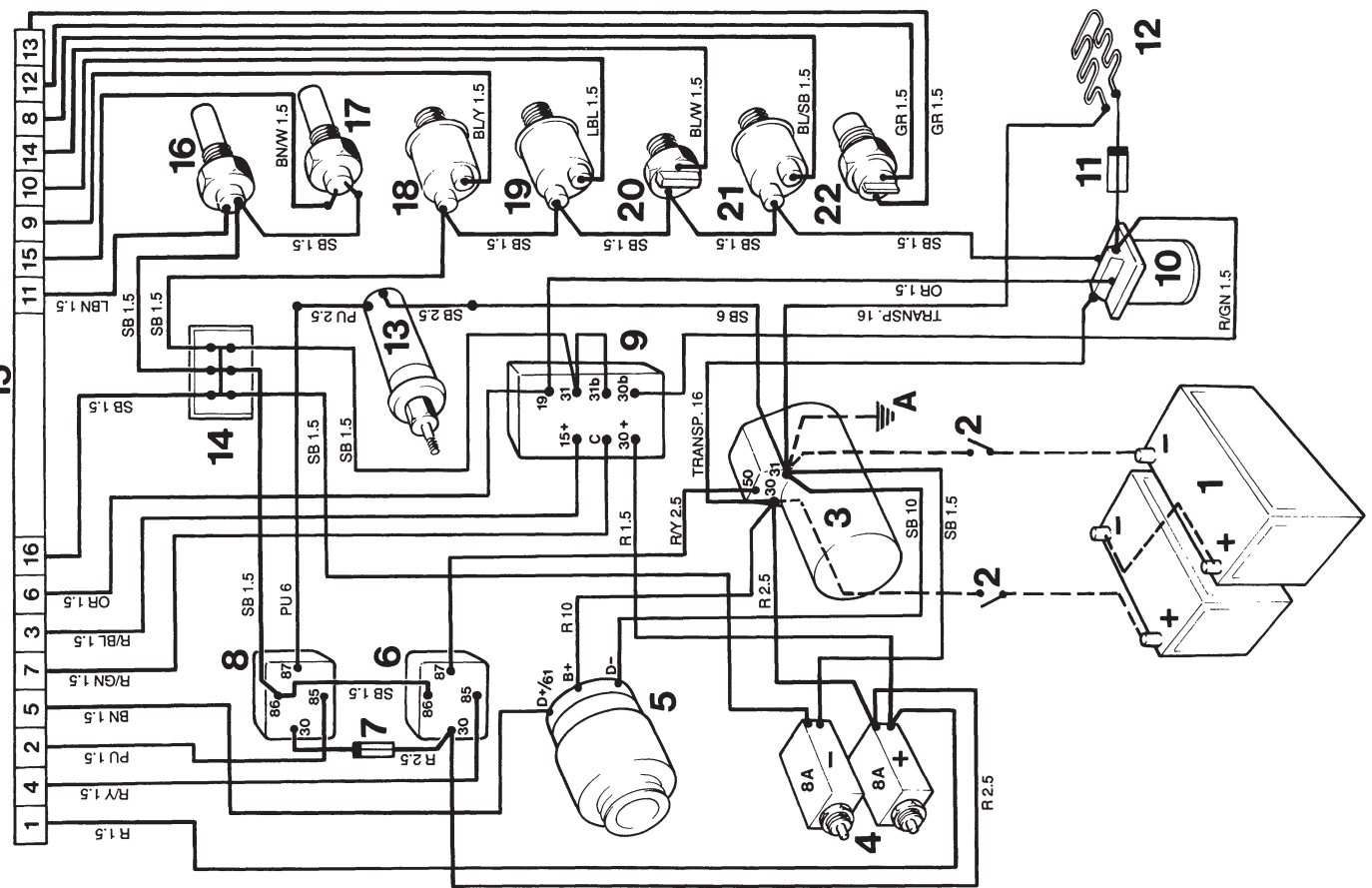

Engine

N.B.: The components in the wiring diagram have the same numbers as shown in the key diagrams on page 45.

- Battery
- Main switch
- Starter motor
- Semi-automatic fuses*
- Alternator
- Start relay*
- 8A or 16A fuse for stop solenoid (24V or 12V system voltage)*
- Stop relay*
- Time relay* (TAMD72 accessory)
- Starter element relay (TAMD72 accessory)
- Fuse (100A) for starter element (TAMD72 accessory)
- Starter element (TAMD72 accessory)
- Stop solenoid
- Ground terminal*
- 16-pole connector*
- Coolant temperature sender
- Coolant temperature switch
- Turbo pressure sender
- Oil pressure sender, engine
- Oil pressure switch, engine
- Oil pressure sender, reverse gear
- Tachometer sender

* Located in junction box

A. Conn. 31 grounded in single-pole system

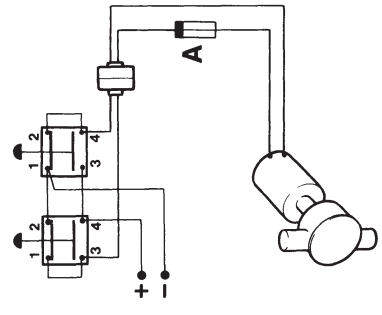

Proposed connection of oil scavenging pump (scavenging and filling).

Cable area 1.5 mm².

A. Fuse (8A/24V, or 15A/12V).

Cable areas in mm² are given after the color code in the wiring diagram.
 Cable areas are 1.0 mm² unless stated otherwise.

Instrument panel (main panel)

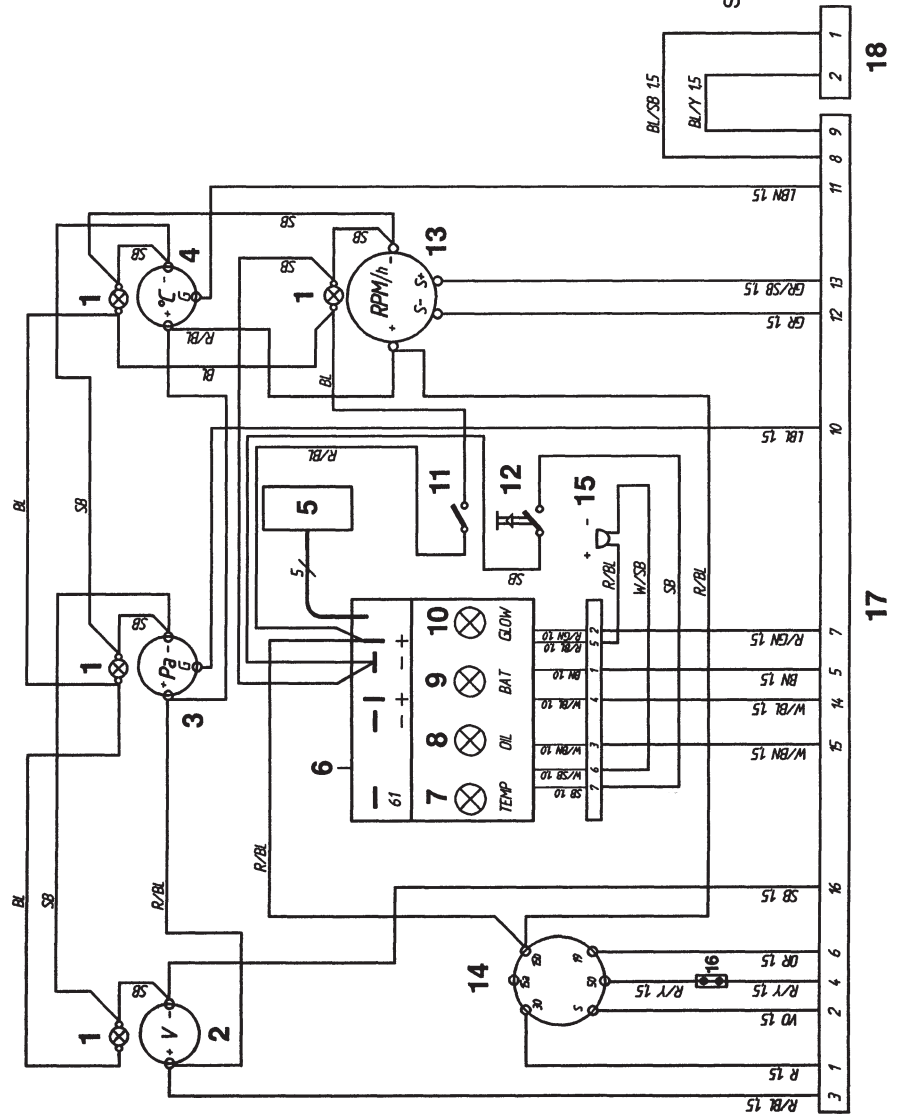

Flying Bridge panel

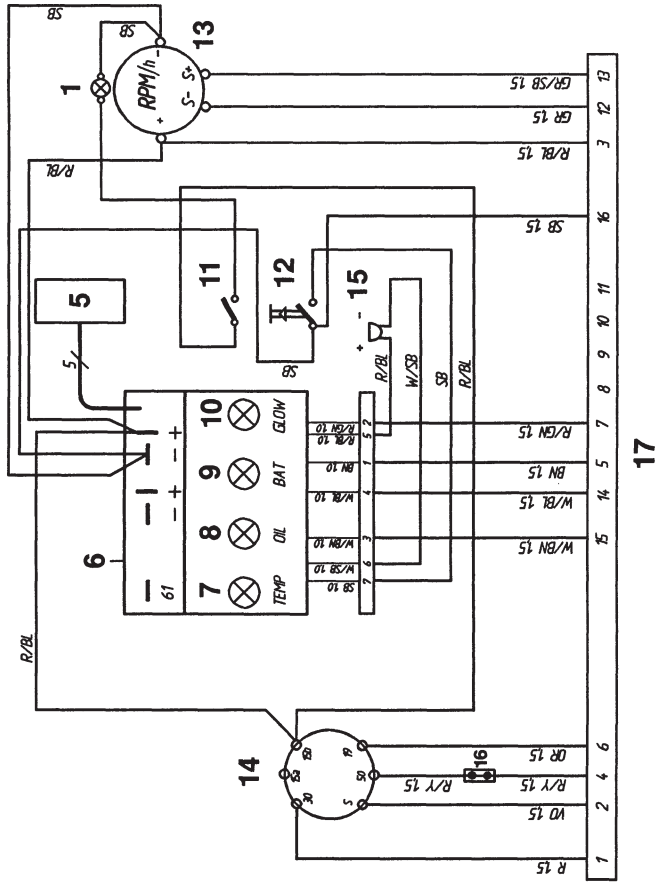

Instrument panels

1. Instrument lighting
2. Voltmeter
3. Oil pressure gauge
4. Coolant temperature gauge
5. Connector for extra warning display (accessory)
6. Electronic unit (alarm)
7. Warning light, coolant temperature
8. Warning light, oil pressure
9. Warning light, charging
10. Control lamp, preheater
11. Switch, instrument lighting
12. Switch, alarm test/acknowledgement
13. Tachometer with built-in hours run meter
14. Key switch
15. Alarm
16. Connector for neutral position switch, if fitted (accessory)
17. 16-pole connection (for supplementary panel, if fitted)
18. 2-pole connection (for supplementary panel, if fitted)

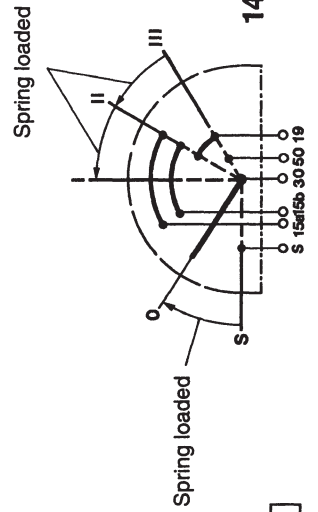

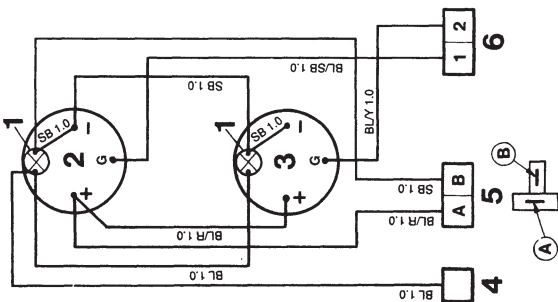

Supplementary panel

1. Instrument lighting
2. Oil pressure gauge, reverse gear
3. Turbo charging pressure gauge
4. Connection to instr. light. on main panel
5. Connection to printed circuit card on main panel
6. Connection to connector (18) on main panel

Cable colors

BL = Blue	OR = Orange
LBL = Light blue	PU = Purple
BN = Brown	R = Red
LBN = Light brown	SB = Black
GN = Green	W = White
GR = Gray	Y = Yellow

Ratio mm²/AWG*

* American Wiring Gauge

mm ²	0.75	1.0	1.5	2.5	10	16
AWG	18	16 (17)	15 (16)	13	7	5

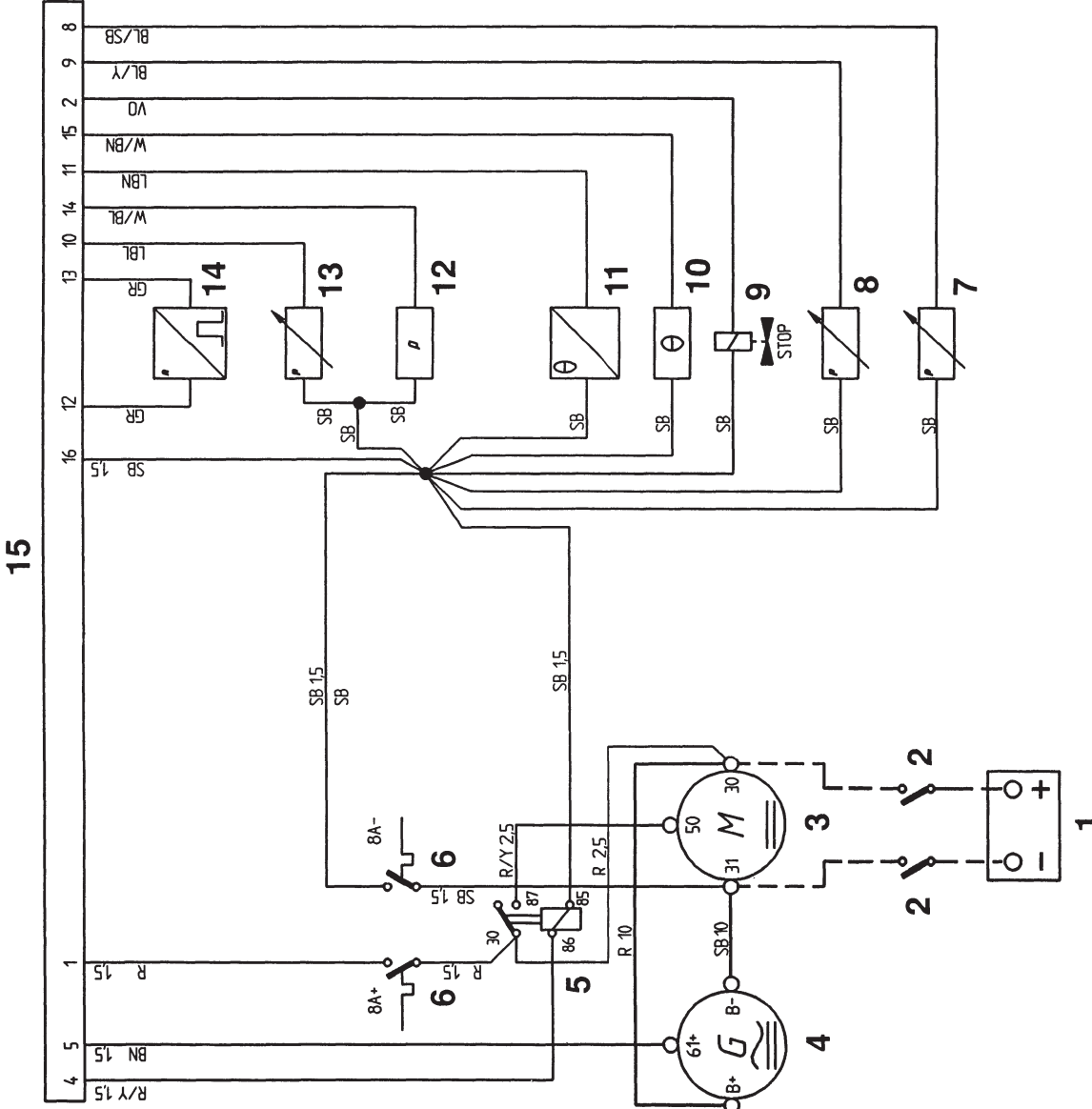

Engine

N.B.: The components in the wiring diagram have the same numbers as shown in the key diagrams on page 46.

1. Battery
 2. Main switch
 3. Starter motor
 4. Alternator
 5. Start relay*
 6. Semi-automatic fuses (8A)*
 7. Oil pressure sender, reverse gear (0 – 30 bar)
 8. Turbo pressure sender (0 – 3 bar)
 9. Solenoid valve (direction valve)
 10. Coolant temperature sender (97°C/207°F), normally open – closes if fault occurs
 11. Coolant temperature sender (40–120°C/104–248°F)
 12. Oil pressure switch, engine (0.7 bar, normally open – closes if fault occurs)
 13. Oil pressure sender, engine (0 – 10 bar)
 14. Tachometer sender
 15. 16-pole connection
- * Located in junction box

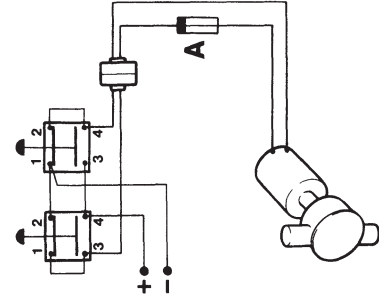

Proposed conn. of oil scavenging pump (scavenging and filling).

Cable area 1.5 mm².

A. Fuse (8A/24V, or 15A/12V).

Cable areas in mm² are given after the color code in the wiring diagram.

Cable areas are 0.75 mm² unless stated otherwise.

The cable marked by a dashed line is not provided by Volvo Penta

TAMD61, TAMD62, TAMD63, TAMD71, TAMD72

Instruments for pilot house

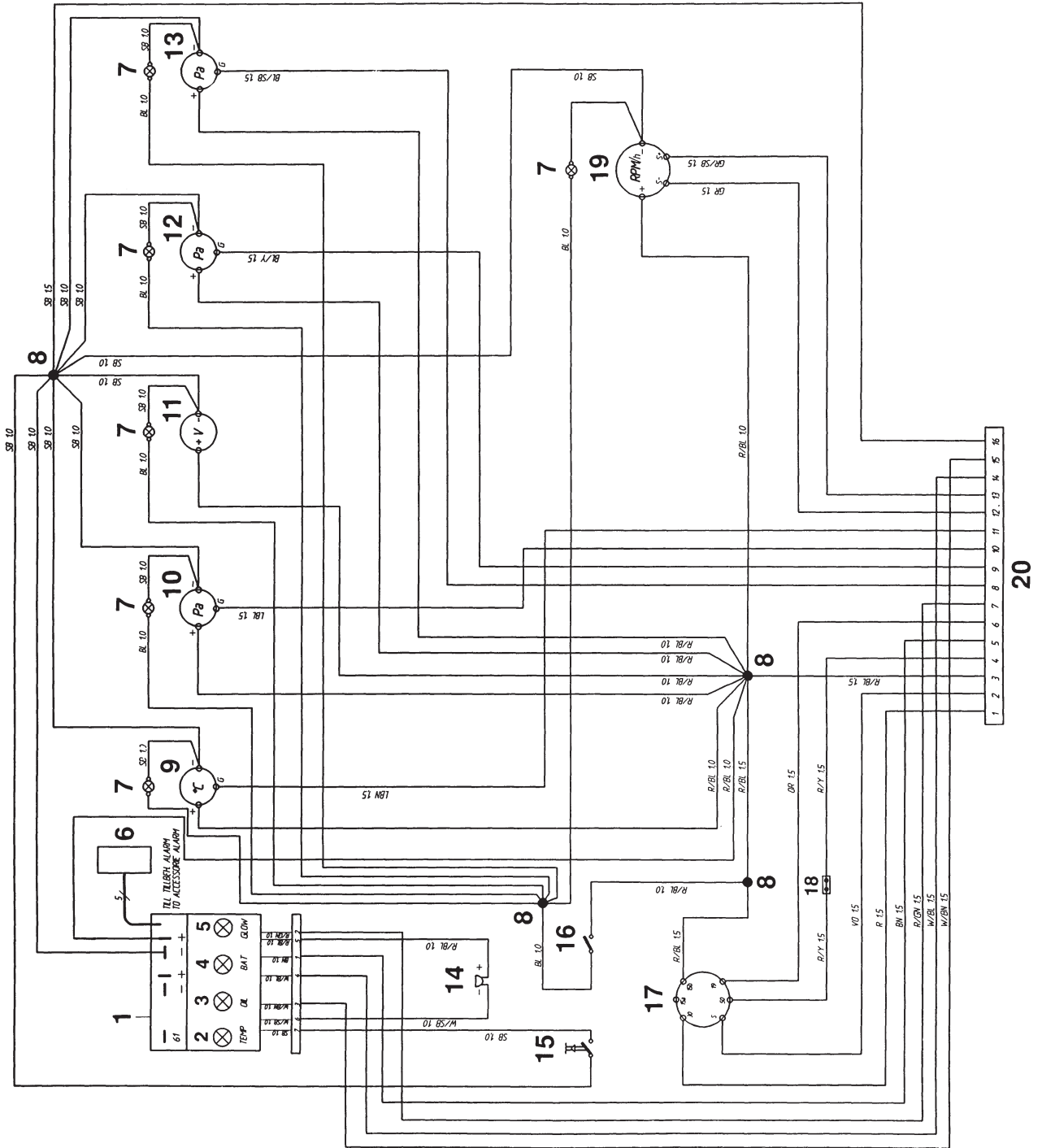

1. Electronic unit (alarm)
2. Warning light, coolant temperature
3. Warning light, oil pressure
4. Warning light, charging
5. Control lamp, preheater
6. Connector for extra warning display (accessory)
7. Instrument lighting
8. Point of connection (fixed)
9. Coolant temperature gauge
10. Oil pressure gauge
11. Voltmeter
12. Turbo charging pressure gauge
13. Oil pressure gauge, reverse gear
14. Alarm
15. Switch, alarm test/acknowledgement
16. Key switch
17. Key switch
18. Connector for neutral position switch, if fitted (accessory)
19. Tachometer with built-in hours run meter
20. 16-pole connection

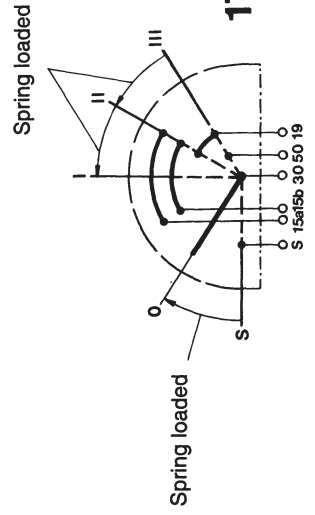

Instruments for Flying Bridge

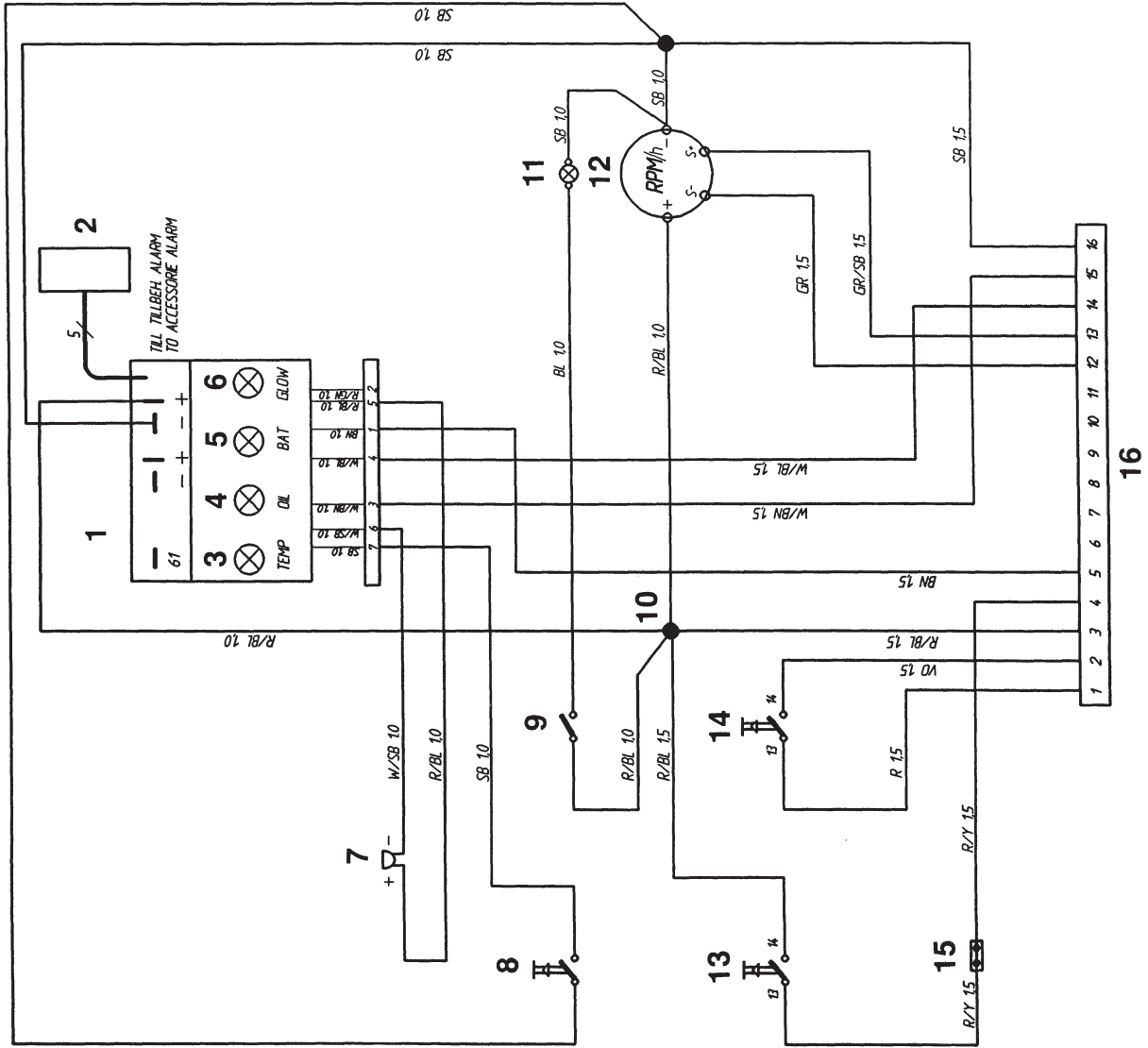

1. Electronic unit (alarm)
2. Connector for extra warning display (accessory)
3. Warning light, coolant temperature
4. Warning light, oil pressure
5. Warning light, charging
6. Control lamp, heating
7. Alarm
8. Switch, alarm test/acknowledgement
9. Switch, instrument lighting
10. Point of connection (fixed)
11. Instrument lighting
12. Tachometer with built-in hours run meter
13. Start button
14. Stop button
15. Connector for neutral position switch, if fitted (accessory)
16. 16-pole connection

Cable colors

BL	=	Blue
LBL	=	Light blue
BN	=	Brown
LBN	=	Light brown
GN	=	Green
GR	=	Gray
OR	=	Orange
R	=	Red
SB	=	Black
VO	=	Violet
W	=	White
Y	=	Yellow

Cable areas in mm² are given after the color code in the wiring diagram.

Inhibiting

 **Warning!** Observe the following when cleaning with high-pressure water jets. Never point the water jet at seals, rubber hoses or electrical components. Never use high-pressure jets when washing the engine.

Boat unused for up to two months

If the boat is not expected to be used for up to two months, it is sufficient to start the engine and warm it up once a fortnight.

If there is a danger of freezing, the cooling system's seawater circuit should be drained after stopping. Check/top up the freshwater system's antifreeze to prevent damage. Drain the freshwater tank if required.

Remove the drain plug (if fitted) on the exhaust pipe condensed water collector. Drain the water from any low-lying parts on the exhaust pipe.

Check the batteries' charge condition. A discharged battery may easily burst.

Boat unused for more than two months

1. Warm the engine up to normal operating temperature.
2. Check that the lubricating oil level in the reverse gear reaches the upper mark ("FULL") on the dipstick. Check the level with the engine idling and the control in neutral.
3. Stop the engine and drain or pump the lubricating oil from the oil sump.
4. **Boat unused for up to 8 months:** Replace the lubricating oil filter and fill with Volvo Penta lubricating oil to the normal level. Warm the engine up after changing the oil.
5. **Boat unused for more than 8 months:** Fill the engine with inhibiting oil to just above the lower part of the mark on the dipstick. The oil companies sell inhibiting oil.

Connect the fuel lines (suction and return) to a can filled with 1/3 inhibiting oil and 2/3 diesel. Some oil companies sell a ready-mixed oil for this purpose.

Vent the fuel system as described on page 37. Start the engine and run it at a fast idle until approx. 2 liters (0.4 Imp. gals/0.5 US gals) have been used from the can.

Stop the engine and drain or pump the lubricating oil from the oil sump. Connect the usual fuel lines.

6. Check that the coolant in the freshwater system has sufficient antifreeze and top up if required; or drain the coolant. Close the sea cock and drain the water from the seawater system. See pages 21–22.

Remove the seawater pump impeller.

7. Check that the batteries are kept well charged. A discharged battery may easily burst.

Batteries always have a certain amount of self-discharge which increases the higher the temperature. Batteries in storage should therefore be kept as cool as possible. They should be kept dry and clean, and they should normally be charged up when the electrolyte density is less than 1.24 g/cm³ (1.20 g/cm³ for tropic acid batteries).

You should preferably remove the batteries and hand them in for maintenance charging as instructed by the manufacturer.

See also point 2 under "Electrical System – Important" on page 48.

8. When necessary, improve the external rust protection by brushing on anti-corrosion oil. The surfaces should be clean and dry before being treated.
N.B.: Some inhibiting oils are flammable. Some are also dangerous to breathe. Ensure good ventilation. Wear a protective mask when spraying.
9. Stick a label on the engine stating the date of inhibition, type of inhibition and the inhibiting oil used.
10. Cover the engine's air intake, exhaust port and the engine itself if so required.

To be done when launching

Check the condition of the propeller(s). Damaged propellers should be reconditioned or replaced.

Bringing out of storage

1. Remove any protective cover over the engine, air intake and exhaust pipe.
2. Remove any external inhibitors using white spirit.
3. Close the drain cocks and fit the drain plugs. Fit the seawater pump impeller using a rotating movement:
TAMD61, 62 and TAMD71, 72 – **counterclockwise**.
TAMD63 – **clockwise**.
Fill the freshwater system if the coolant has been drained. See "Filling with coolant" on page 41. For coolant, see page 14.
4. If necessary, fill the engine with lubricating oil of the correct quality. Fit a new oil filter if this has not been done when changing the oil during inhibiting. Check the oil level in the reverse gear.
5. Check the batteries as described on page 49. Connect the batteries.
6. Fit new fuel filters and vent the fuel system as described on pages 36 and 37.
7. Open the sea cock. Start the engine (see "Operation") and warm the engine up at a fast idle before loading the engine.
8. Check for any leaks of oil, fuel or cooling water.

Troubleshooting

1. Engine does not start

Starter motor does not turn engine over

CAUSE	REMEDY
<ul style="list-style-type: none"> The reverse gear is not disengaged (applies to control with neutral position switch) 	Put the reverse gear control lever into neutral
<ul style="list-style-type: none"> Discharged batteries 	Charge/replace the batteries (or connect up auxiliary batteries as shown on page 17)
<ul style="list-style-type: none"> Main switches off 	Switch on the main switches
<ul style="list-style-type: none"> One of the semi-automatic fuses in the junction box has tripped (pos. 4 in the engine's wiring diagram on page 53, or pos. 6 in diagram on page 55) 	Reset the fuse by pressing the button on it
<ul style="list-style-type: none"> Poor contact/break, electrical leads 	Rectify any break/loose connections. Check that the connections are not oxidized. If required, clean them and spray with moisture-repellent spray. See wiring diagrams, pp. 52–57
<ul style="list-style-type: none"> Faulty key switch 	Replace key switch
<ul style="list-style-type: none"> Faulty start relay 	Replace start relay (or change temporarily with stop relay*)
<ul style="list-style-type: none"> Faulty starter motor/solenoid (control solenoid) 	Contact authorized service personnel
<ul style="list-style-type: none"> Water in the engine 	Contact authorized service personnel. Do not try to start the engine if you think there is water in it

*N.B.: TAMD63 has no stop relay.

Starter motor turns over slowly

CAUSE	REMEDY
<ul style="list-style-type: none"> Discharged batteries 	Charge/replace the batteries (or connect up auxiliary batteries as shown on page 17)
<ul style="list-style-type: none"> Poor contact, electrical leads 	Rectify any loose connections. Check that the connections are not oxidized. If required, clean them and spray with moisture-repellent spray

Starter motor turns over as normal but engine does not start

CAUSE	REMEDY
<ul style="list-style-type: none"> Air in fuel system 	Vent the fuel system as shown on page 37
<ul style="list-style-type: none"> Lack of fuel <ul style="list-style-type: none"> fuel cocks closed fuel tank empty/wrong tank connected blocked fuel filters (due to contaminants/paraffin precipitation in the fuel as a result of low outside temp.) 	Open the fuel cocks Fill with fuel/connect the correct fuel tank Fit new fuel filters (pre-filter and/or fine filters). Vent the system as shown on page 37
<ul style="list-style-type: none"> Stop solenoid* incorrectly connected/seizing 	Check stop solenoid has not been switched on unintentionally
<ul style="list-style-type: none"> TAMD63: Solenoid valve incorrectly connected 	Check solen. valve has not been switched on unintentionally
<ul style="list-style-type: none"> Insufficient preheating** <ul style="list-style-type: none"> incorrect starting procedure starter element not switched on 	Try starting again as shown on page 16 Check that none of the semi-automatic fuses has tripped (pos. 4 in the engine's wiring diagram on page 53). Reset the fuse by pressing the button on it Check the electrical leads and key switch, start relay and high power relay (change the start relay temporarily with stop relay* if required). Contact authorized service personnel if the starter element needs to be replaced

* TAMD63 has no stop solenoid.

** TAMD63 and TAMD72 have no starter element.

2. Engine starts but stops again/runs unevenly

CAUSE	REMEDY
<ul style="list-style-type: none">• Air in fuel system	Vent the fuel system as shown on page 37
<ul style="list-style-type: none">• Lack of fuel<ul style="list-style-type: none">– fuel cocks closed– fuel tank empty/wrong tank connected– blocked fuel filters (due to contaminants/paraffin precipitation in the fuel as a result of low outside temp.)	Open the fuel cocks Fill with fuel/connect the correct fuel tank Fit new fuel filters (pre-filter and/or fine filters). Vent the system as shown on page 37
<ul style="list-style-type: none">• Insufficient preheating*<ul style="list-style-type: none">– incorrect starting procedure– starter element not switched on	Try starting again as shown on page 16 Check that none of the semi-automatic fuses has tripped (pos. 4 in the engine's wiring diagram on page 53). Reset the fuse by pressing the button on it Check the electrical leads and key switch, start relay and high power relay (change the start relay temporarily with stop relay* if required). Contact authorized service personnel if the starter element needs to be replaced
<ul style="list-style-type: none">• Insufficient air flow to engine<ul style="list-style-type: none">– blocked air filter	Fit a new air filter/clean air filter, check ventilation to engine compartment
<ul style="list-style-type: none">• Break in pressure pipe(s)	Fit new pressure pipe(s)

*N.B.: TAM63 and TAM72 have no starter element.

3. Coolant temperature too high

CAUSE	REMEDY
<ul style="list-style-type: none">• Coolant level in engine too low (air in system)	Fill engine with coolant and vent system as shown on page 41
<ul style="list-style-type: none">• Faulty thermostat	Fit a new thermostat
<ul style="list-style-type: none">• Faulty seawater pump (pump impeller)	Replace the seawater pump impeller as shown on page 44
<ul style="list-style-type: none">• Sea cock closed	Open the boat's sea cock
<ul style="list-style-type: none">• Seawater intake blocked	Clean the seawater intake
<ul style="list-style-type: none">• Seawater filter blocked	Clean the seawater filter as shown on page 41
<ul style="list-style-type: none">• Heat exchanger insert blocked	Clean the insert(s) as shown on page 42
<ul style="list-style-type: none">• Faulty circulation pump	Contact authorized service personnel

4. Coolant temperature too low

CAUSE	REMEDY
<ul style="list-style-type: none">• Faulty thermostat	Fit a new thermostat

5. Engine does not reach correct speed at full throttle

CAUSE	REMEDY
<ul style="list-style-type: none"> • Boat abnormally loaded 	If possible, reduce/redistribute the load
<ul style="list-style-type: none"> • Fouling on bottom of boat 	Clean the bottom of the boat and treat it with anti-fouling paint
<ul style="list-style-type: none"> • Faulty/damaged propeller 	Replace the propeller
<ul style="list-style-type: none"> • Insufficient fuel flow <ul style="list-style-type: none"> – fuel filters blocked (due to contaminants/paraffin precipitation in the fuel as a result of low outside temp.) 	Fit new fuel filters (pre-filter and/or fine filters). Vent the system as shown on page 37
<ul style="list-style-type: none"> • Water in fuel 	Clean the fuel tank. Drain water from the pre-filter, if fitted.
<ul style="list-style-type: none"> • Insufficient air flow to engine <ul style="list-style-type: none"> – air filter blocked 	Fit new air filters/clean air filter
<ul style="list-style-type: none"> – air leak betw. turbo and engine's inlet manifold 	Check the rubber hose between the turbo and the conn. pipe, plus other connections. Tighten the hose clips
<ul style="list-style-type: none"> – faulty turbocharger 	Contact authorized service personnel
<ul style="list-style-type: none"> – poor engine compartment ventilation 	Check that the ventilating ducts to the engine compartment are not blocked
<ul style="list-style-type: none"> • Throttle controls incorrectly adjusted 	Adjust the throttle controls
<ul style="list-style-type: none"> • Charge air cooler blocked 	Clean the insert(s) as shown on page 42
<ul style="list-style-type: none"> • Faulty bypass valve* 	Contact authorized service personnel
<ul style="list-style-type: none"> • Great back pressure in exhaust system 	Check that the exhaust pipe is not restricted
<ul style="list-style-type: none"> • Faulty injectors 	Get authorized service personnel to check the injectors
<ul style="list-style-type: none"> • Faulty setting of injection pump 	Contact authorized service personnel
<ul style="list-style-type: none"> • Fault in smoke limiter <ul style="list-style-type: none"> – smoke limiter seizing 	Contact authorized service personnel
<ul style="list-style-type: none"> – pressure pipe between inlet manifold and smoke limiter leaking 	Fit a new pressure pipe
<ul style="list-style-type: none"> – faulty diaphragm in smoke limiter 	Contact authorized service personnel
<ul style="list-style-type: none"> – faulty setting 	Contact authorized service personnel

* **N.B.:** TAMD63 and TAMD72 have no bypass valve.

6. Engine runs on

CAUSE	REMEDY
<ul style="list-style-type: none"> • Fuse broken (pos. 7 in wiring diagram page 53) 	Replace the fuse (16A for 12V, or 8A for 24V system voltage)
<ul style="list-style-type: none"> • One of the semi-automatic fuses in the junction box has tripped (pos. 4 in the engine's wiring diagram on page 53, or pos. 6 in diagram on page 55) 	Reset the fuse by pressing the button on it
<ul style="list-style-type: none"> • Poor contact/break, electrical leads 	Rectify any break/loose connections. Check that the connections are not oxidized. If required, clean them and spray with moisture-repellent spray. See wiring diagrams, pp. 52–55
<ul style="list-style-type: none"> • Faulty key switch 	Replace key switch
<ul style="list-style-type: none"> • Faulty stop relay* 	Replace stop relay (or change temporarily with start relay)
<ul style="list-style-type: none"> • TAMD61, 62, TAMD71, 72: Faulty stop solenoid 	Contact authorized service personnel**
<ul style="list-style-type: none"> • TAMD61, 62, TAMD71, 72: Stop controls incorrectly adjusted/seizing 	Contact authorized service personnel**
<ul style="list-style-type: none"> • TAMD63: Faulty solenoid valve (direction valve) 	Contact authorized service personnel

* TAMD63 has no stop relay.

** The stop solenoid should be adjusted by authorized service personnel. Incorrect adjustment may destroy the solenoid.

Technical Data

General

	TAMD61A, TAMD62A, TAMD63L-A, TAMD63P-A	TAMD71A, TAMD71B	TAMD72A, TAMD72WJ-A
No. of cylinders	6	6	6
Swept volume	5.48 dm ³ (liters), (334 in ³)		6.73 dm ³ (liters), (411 in ³)
Low idle	600 ±20 r/min.		600 ±30 r/min.
Valve clearance, stopped engine, cold or hot, TAMD63L, TAMD63P:			
inlet	0.50 mm (0.0197")	—	—
outlet	0.65 mm (0.0256")	—	—
other engines:			
inlet	0.40 mm (0.0157")	0.40 mm (0.0157")	0.50 mm (0.0197")
outlet	0.55 mm (0.0217")	0.55 mm (0.0217")	0.65 mm (0.0256")
Weight, engine with heat exchanger, no reverse gear or clutch, approx.:			
TAMD63L, TAMD63P:	745 kg (1643 lbs)	—	—
other engines	770 kg (1698 lbs)	880 kg (1940 lbs)	890 kg (1962 lbs)

Lubricating system

Oil pressure, hot engine, operating speed	300–550 kPa (3.0–5.5 kp/cm ² = 43–80 psi)	420–650 kPa (4.2–6.5 kp/cm ² = 61–94 psi)
at idling speed	min. 150 kPa (1.5 kp/cm ² = 21 psi)	min. 150 kPa (1.5 kp/cm ² = 21 psi)
Max. engine tilt, operating, TAMD63L, TAMD63P ...	10°	—
other engines	15°	15°
Oil capacity at oil change, without oil filter*, approx.:		
no engine tilt, Max.	20 liters (4.4 Imp. gals/5.3 US gals)	30 liters (6.6 Imp. gals/7.9 US gals)
Min.	14 liters (3.1 Imp. gals/3.7 US gals)	—
5° engine tilt (TAMD63L, TAMD63P), Max.	17 liters (3.7 Imp. gals/4.5 US gals)	—
Min.	11 liters (2.4 Imp. gals/2.9 US gals)	—
10° engine tilt (TAMD63L, TAMD63P), Max.	13 liters (2.9 Imp. gals/3.4 US gals)	—
Min.	8 liters (1.8 Imp. gals/2.1 US gals)	—
15° engine tilt (other engines)**	9 liters (2.0 Imp. gals/2.4 US gals)	13 liters (2.9 Imp. gals/3.4 US gals)

* The lubricating oil filter and bypass filter each hold approx. 0.5 liter (0.5 quart).

** At an engine tilt of >5° backwards, oil dipstick part No. 863166-5 should be used.

Oil quality	VDS (Volvo Drain Specification), or CD or CE in acc. with API system	VDS (Volvo Drain Specification), or CD or CE in acc. with API system
-------------------	---	---

Viscosity at various outside air temperatures

(The temperature values refer to constant outside air temperatures).

* Refers to synthetic or semi-synthetic oil.
N.B.: SAE 5W/30 only may be used.

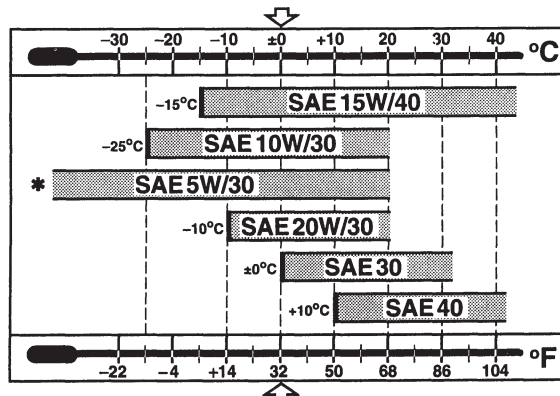

Fuel system

	TAMD61A, TAMD62A, TAMD63L–A, TAMD63P–A	TAMD71A, TAMD71B	TAMD72A, TAMD72WJ–A
Injection pump, settings:			
TAMD63L and TAMD71A	16° ±0.5° B.T.D.C.	20° ±0.5° B.T.D.C.	–
TAMD63P and TAMD72WJ	15° ±0.5° B.T.D.C.	–	18° ±0.5° B.T.D.C.
Other engines	18° ±0.5° B.T.D.C.	22° ±0.5° B.T.D.C.	15° ±0.5° B.T.D.C.
Injectors, opening pressure			
TAMD63L and TAMD71A	29 (+0.8) MPa (295 (+8) kp/cm ² = 4206 (+116) psi)	27 MPa (275 kp/cm ² = 3916 psi)	–
TAMD63P	30 (+0.8) MPa (306 (+8) kp/cm ² = 4351 (+116) psi)	–	–
Other engines	25 (+0.8) MPa (255 (+8) kp/cm ² = 3626 (+116) psi)	30 (+0.8) MPa (306 (+8) kp/cm ² = 4351 (+116) psi)	29 (+0.8) MPa (295 (+8) kp/cm ² = 4206 (+116) psi)
Adjustment pressure (new spring):			
TAMD63L and TAMD71A	29.5 (+0.8) MPa (300 (+8) kp/cm ² = 4279 (+116) psi)	27.5–28.3 MPa (280–289 kp/cm ² = 3989–4105 psi)	–
TAMD63P	30.5 (+0.8) MPa (311 (+8) kp/cm ² = 4424 (+116) psi)	–	–
Other engines	25.5–26.3 MPa (260–268 kp/cm ² = 3699–3815 psi)	30.5 (+0.8) MPa (311 (+8) kp/cm ² = 4424 (+116) psi)	29.5 (+0.8) MPa (300 (+8) kp/cm ² = 4279 (+116) psi)

Cooling system

Freshwater sys. capac., incl. heat exch., approx.	30 liters (TAMD61, TAMD62), (6.6 Imp. gals/7.9 US gals) 27 liters (TAMD63), (5.9 Imp. gals/7.1 US gals)	35 liters, (7.7 Imp. gals/9.3 US gals) –
Thermostat starts to open at	73–77°C (163–171°F)	73–77°C (163–171°F)
fully open at	86–90°C (187–194°F)	86–90°C (187–194°F)

Electrical system

System voltage	12V (or 24V)	24V (or 12V)
Alternator, voltage/max. amperage:		
TAMD61, 62 and TAMD71, 72	14V/60A (or 28V/60A)	28V/60A (or 14V/60A)
TAMD63	14V/60A (or 28V/40A)	–
Alternator output approx.:		
TAMD61, 62 and TAMD71, 72	840 W (or 1700 W)	1700 W (or 840 W)
TAMD63	840 W (or 1120 W)	–
Alternative alternator equipment (accessory)*:		
for 12V elec. system, voltage/max. amperage	14V/130A	14V/130A
output approx.	1800 W	1800 W
for 24V elec. system, voltage/max. amperage	28V/100A	28V/100A
output approx.	2800 W	2800 W
Battery capacity:		
in 12V electrical system	2 x 12V connected in parallel, max. 110 Ah (total max. 220 Ah)	2 x 12V connected in parallel, max. 110 Ah (total max. 220 Ah)
in 24V electrical system	2 x 12V connected in series, max. 143 Ah	2 x 12V connected in series, max. 143 Ah
Battery electrolyte density at +25°C (77°F):		
fully charged battery	1.28 g/cm ³ (1.24 g/cm ³)**	1.28 g/cm ³ (1.24 g/cm ³)**
recharge battery at	1.24 g/cm ³ (1.20 g/cm ³)**	1.24 g/cm ³ (1.20 g/cm ³)**

* Not available for TAMD61 pleasure boat or for TAMD62 or TAMD63.

** **N.B.:** Applies to tropic acid batteries

Turbocharger

Charging pressure, min. values (measured in the engine's inlet manifold at 100% load and full throttle, air temperature approx. +25°C/77°F). When measuring at a different temperature, the charging pressure measured must be corrected: see workshop manual. If full power cannot be achieved, the pressure is considerably lower.

	TAMD61A	TAMD62A	TAMD63L-A	TAMD63P-A
Power curve PD ("Pleasure Craft Duty")				
2400 r/min.	–	–	–	200 kPa
2500 r/min.	161 kPa	188 kPa	–	–
2600 r/min.	–	188 kPa	–	215 kPa
2800 r/min.	179 kPa	197 kPa	180 kPa	225 kPa
Power curve LD ("Light Duty")				
2400 r/min.	161 kPa	–	–	–
2500 r/min.	–	–	180 kPa	–
2800 r/min.	179 kPa	–	–	–
Power curve MD ("Medium Duty")				
2200 r/min.	115 kPa	–	–	–
2500 r/min.	84 kPa	–	120 kPa	–
TAMD71A TAMD71B TAMD72A TAMD72WJ-A				
Power curve PD ("Pleasure Craft Duty")				
2500 r/min.	–	188 kPa	230 kPa	–
2600 r/min.	–	188 kPa	230 kPa	175 kPa
Power curve SLD ("Special Light Duty")				
2400 r/min.	182 kPa	–	–	–
2500 r/min.	183 kPa	188 kPa	230 kPa	–
2600 r/min.	–	188 kPa	230 kPa	175 kPa
Power curve LD ("Light Duty")				
2400 r/min.	182 kPa	–	–	–
2500 r/min.	183 kPa	–	–	–
Power curve MD ("Medium Duty")				
2200 r/min.	136 kPa	–	–	–
2400 r/min.	144 kPa	–	–	–
2500 r/min.	153 kPa	–	–	–
Power curve HD ("Heavy Duty")				
1800 r/min.	71 kPa	–	–	–
2000 r/min.	89 kPa	–	–	–

Reverse gear

MPM

	IRM 220A-1		IRM 301 A-2*
Type designation	IRM 220A-1	–	IRM 301 A-2*
Gear ratios	1.53:1; 2.04:1	–	1.516:1; 2.006:1
Angle (output shaft)	10°	–	10°
Oil capacity approx.	4 liters (0.9 Imp. gals/ 1.05 US gals)	–	7.5 liters (1.6 Imp. gals/ 2.0 US gals)
Oil quality (in acc. with API system)	CC, CD, CE	–	CC, CD, CE
Viscosity	SAE30**	–	SAE30**
Working oil pressure during operation	2.0–2.2 MPa (20.4–22.4 kp/cm ² = 290–319 psi)	–	2.1–2.3 MPa (21.4–23.5 kp/cm ² = 305–334 psi)
Approx. weight	53 kg (117 lbs)	–	155 kg (342 lbs)

* Applies to TAMD72A.

** N.B.: Only **single grade** lubricating oil (only **one** viscosity number) may be used in the reverse gears.

	TAMD61A, TAMD62A, TAMD63L-A, TAMD63P-A	TAMD71A, TAMD71B	TAMD72A
Twin Disc			
Type designation	MG5061SC*	-	-
Gear ratios	2.43:1; 3.00:1	-	-
Angle (output shaft)	0°	-	-
Oil capacity approx.	3.4 liters (0.75 Imp. gals/0.9 US gals)	-	-
Oil quality (in acc. with API system)	CC, CD, CE	-	-
Viscosity at oil temp. of 66–85°C (151–185°F)	SAE30**	-	-
at oil temp. of 85–100°C (185–212°F)	SAE40**	-	-
Working oil pressure at oil temp. of 82°C (180°F):			
engaged, 1800 r/min.	2.3 MPa, (23.5 kp/cm ² = 334 psi)	-	-
at cruising speed, min.	2.07 MPa, (21.1 kp/cm ² = 300 psi)	-	-
Approx. weight	117 kg (258 lbs)	-	-

* Applies only to TAMD61A.

** **N.B.:** Only **single grade** lubricating oil (only **one** viscosity number) may be used in the reverse gears.

Type designation	MG5061A	MG5061A	-
Gear ratios	2.01:1; 2.47:1*	1.75:1; 2.01:1; 2.47:1	-
Angle (output shaft)	7°		-
Oil capacity approx.	3.2 liters (0.7 Imp. gals/ 0.85 US gals)		-
Oil quality (in acc. with API system)	CC, CD, CE		-
Viscosity at oil temp. of 66–85°C (151–185°F)	SAE30**		-
at oil temp. of 85–100°C (185–212°F)	SAE40**		-
Working oil pressure at oil temp. of 82°C (180°F):			
engaged, 1800 r/min.	2.3 MPa (23.5 kp/cm ² = 334 psi)		-
at cruising speed, min.	2.07 MPa (21.1 kp/cm ² = 300 psi)		-
Approx. weight	113 kg (249 lbs)		-

* Applies only to TAMD61A.

** **N.B.:** Only **single grade** lubricating oil (only **one** viscosity number) may be used in the reverse gears.

Type designation	-	MG507-1	MG507-1
Gear ratios	-	1.10:1; 1.51:1; 1.77:1; 1.98:1; 2.54:1; 2.99:1	1.10:1; 1.51:1; 1.77:1; 1.98:1
Angle (output shaft)	-	0°	
Oil capacity approx.	-	6.7 liters (1.5 Imp. gals/1.8 US gals)	
Oil quality (in acc. with API system)	-	CC, CD, CE	
Viscosity at oil temp. of 66–85°C (151–185°F)	-	SAE30*	
at oil temp. of 80–99°C (176–210°F)	-	SAE40*	
Working oil pressure at oil temp. of 82°C (180°F):			
engaged, 1800 r/min.	-	2.05–2.2 MPa (20.9–22.4 kp/cm ² = 297–319 psi)	
at cruising speed, min.	-	1.9 MPa (19.3 kp/cm ² = 276 psi)	
Approx. weight	-	178 kg (392 lbs)	

** **N.B.:** Only **single grade** lubricating oil (only **one** viscosity number) may be used in the reverse gears.

	TAMD61A	TAMD71A, TAMD71B	TAMD72A
Type designation	MG507A-1		MG507A-1
Gear ratios	2.54:1		1.51:1; 1.77:1; 1.98:1
Angle, output shaft	7°		7°
Oil capacity approx.	6.7 liters (1.5 Imp. gals/ 1.8 US gals)		6.7 liters (1.5 Imp. gals/ 1.8 US gals)
Oil quality (in acc. with API system)	CC, CD, CE		CC, CD, CE
Viscosity at oil temp. of 66–85°C (151–185°F)	SAE30*		SAE30**
at oil temp. of 80–99°C (176–210°F)	SAE40*		SAE40**
Working oil pressure at oil temp. of 82°C (180°F): engaged, 1800 r/min.	2.05–2.2 MPa (20.9–22.4 kp/cm ² = 297–319 psi)		2.05–2.2 MPa (20.9–22.4 kp/cm ² = 297–319 psi)
at min. cruising speed	1.9 MPa (19.3 kp/cm ² = 276 psi)		1.9 MPa (19.3 kp/cm ² = 276 psi)z
Approx. weight	178 kg (392 lbs)		178 kg (392 lbs)

*N.B.: Only **single grade** lubricating oil (only **one** viscosity number) may be used in the reverse gears.

Clutch

**Disengageable clutches at front of engine
(accessory, TAMD71A)**

Rockford/Borg Warner

Type	–	Single disk clutch ("over-center" type)	–
Gear ratio	–	1:1	–
Size	–	203 mm (8") or 254 mm (10")	–
Permitt. engine speed, power take-off engaged ...	–	900–1800 r/min.	–
Approx. weight	–	65 kg (143 lbs)	–

**Disengageable clutch at rear of engine
(accessory, TAMD71A auxiliary engine)**

Automotive Products

Type	–	Double disk clutch ("over-center" type)	–
Gear ratio	–	1:1	–
Size	–	292 mm (11 1/2")	–
Approx. weight	–	83 kg (183 lbs)	–

Accessories

Volvo Penta accessories

Below is a selection of products which can be purchased as accessories

N.B.: Not all accessories can be fitted to all engines. Ask your Volvo Penta service dealer for advice.

- Volvo Penta lubricating oils:
 - VDS*, SAE 15W/40
- Volvo Penta antifreeze (glycol) for the freshwater system
- Volvo Penta anti-corrosive agent for the freshwater system
- Extra instrument panels:
 - Supplementary panel
 - Panel for Flying Bridge (alternative operating position)
 - Extra alarm panel
- Extra alternator incl. regulator to be fitted at the front of the engine:
 - 14V/130A (1800W)
 - 28V/100A (2800W)
- Extra fuel pre-filter with water separator:
 - Single or double
- Separate located lubricating oil filter
- Bypass filter for engine lubricating oil (standard, TAMD63)
- Electric oil scavenging pump (12V or 24V)
- Manual oil scavenging pump
- Seawater filter
- Separate expansion tank
- Hot water outlet
- Exhaust riser
- Silencer
- Bilge/scavenging pumps, 24V (TAMD71 in commercial operation). Capacity at 1800 r/min. and 3 m (9.8 ft) suction height:
 - 1 1/4" – 230 l/min.
 - 2" – 300 l/min.
- Hydraulic pump (only for engine with seawater pump)
- Trolling valve for Twin Disc reverse gears MG507-1 and MG507A-1
- Extra power take-off at the front of the engine (engines in commercial operation)

TAMD61A, TAMD62, TAMD71A: Pulley, mounted on crankshaft. Max. output 7.35 kW. Outer diam. Ø 158 mm (6.220").

TAMD71A: Disengageable clutches, gear ratio 1:1.

– Rockford BW 203 mm (8"). Max. output at 1800 r/min. 58 hp. Max. torque 226 Nm (23 kpm/170.2 ft.lbs).

– Rockford BW 254 mm (10"). Max. output at 1800 r/min. 80 hp. Max. torque 314 Nm (32 kpm/236.8 ft.lbs).

- Toolkit

* VDS oil allows longer intervals between oil changes (see maintenance schedule on page 24).

** Must not be used together with antifreeze (glycol).

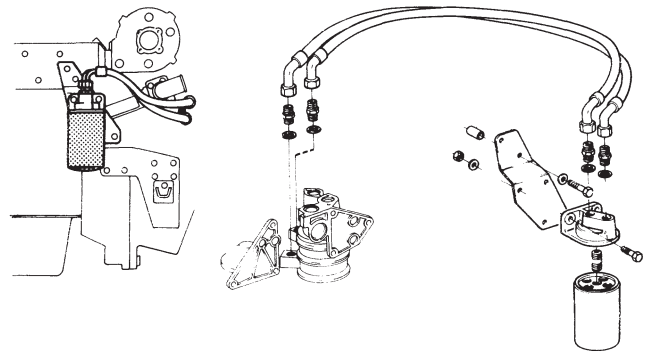

Location of separate lubricating oil filter

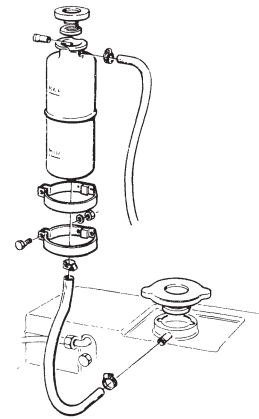

Connecting the separate expansion tank

Hot water outlet:

Location of angular nipples and cock (thread: 1/2"-14 NPTF)

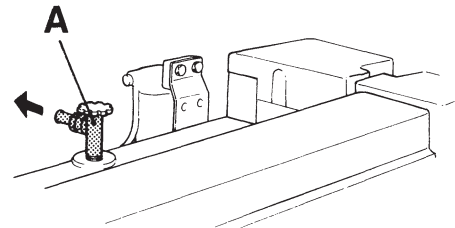

A. Angular nipple and cock (outlet)

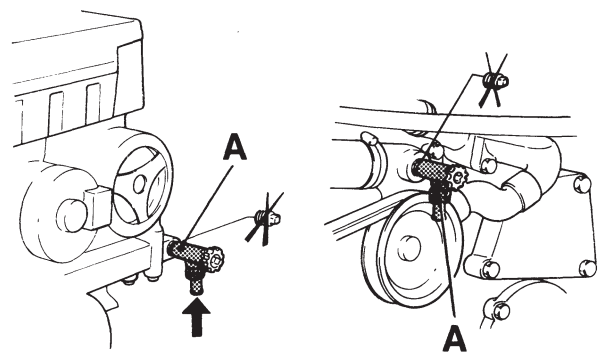

TAMD61, 62, 71, 72

TAMD63

A. Angular nipple and cock (inlet)

Maintenance – Equipment, Accessories

Controls

On Volvo Penta controls, the control lever has an adjustable friction brake. Lever movements can thereby be adapted according to personal requirements.

Dual lever controls have individually adjustable friction brakes for each lever.

Adjusting the friction brake

Single lever control

This brake is intended for controlling speed and is adjusted at **half throttle with the reverse gear engaged**. The brake does not affect gearing.

1. Remove the cover over the control.
2. Adjust the friction by turning the screw at the arrow (see figure).

Turning the screw **clockwise (+)** makes the lever movement **heavier**, while turning **counterclockwise (-)** consequently makes it **easier** to move the lever.

3. Fit the cover over the control.

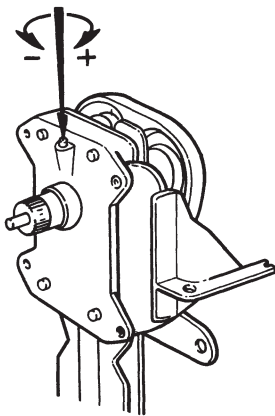

Adjusting the friction brake on single lever controls (single or dual)

Dual lever control

The brake is intended for controlling speed.

Adjust the friction by turning the screw at the arrow (see figure).

Turning the screw **clockwise (+)** makes the lever movement **heavier**, while turning **counterclockwise (-)** consequently makes it **easier** to move the lever.

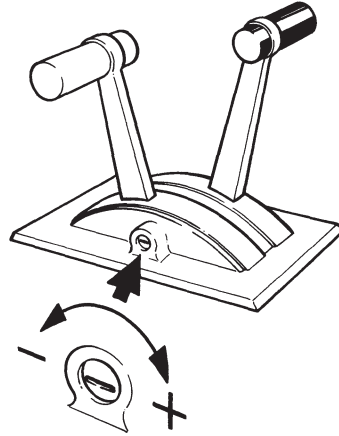

Adjusting the friction brake on dual lever controls

