

VOLVO PENTA INBOARD DIESEL

MD22L

4-cylinder, direct-injected, freshwater-cooled marine diesel engine
Crankshaft power* 36.5 kW (50 hp)

* Power rating – see Technical Data

The MD22L is a marine engine of advanced design manufactured from quality components and designed to fulfil customer requirements.

Service Life

The MD22L is fitted with freshwater cooling as standard. This reduces internal corrosion and enables the engine to maintain a consistent and optimal working temperature under all conditions.

Comfort

Smooth running with very low vibration levels results from a dynamically balanced design and high efficiency rubber insulation.

The engine's high torque provides excellent operating characteristics to aid maneuvering, particularly in confined spaces.

Additional on board comfort features are available from an extensive range of matched accessories.

Environment

The engine's direct injection and advanced combustion system ensure high efficiency and low fuel consumption, which minimize noxious exhaust emissions and enhance overall enjoyment of boating.

Transmissions

For increased flexibility, in both design and installation, the following complete matched transmission units are available:

- HS25A, MS25A and MS25L reverse gears, both down angle and straight
- 120S – the exceptionally smooth and quiet sail drive, also allowing the engine to be installed in reverse position using a kit.

All units are built for durability and smooth operation.

MD22L with 120S S-drive

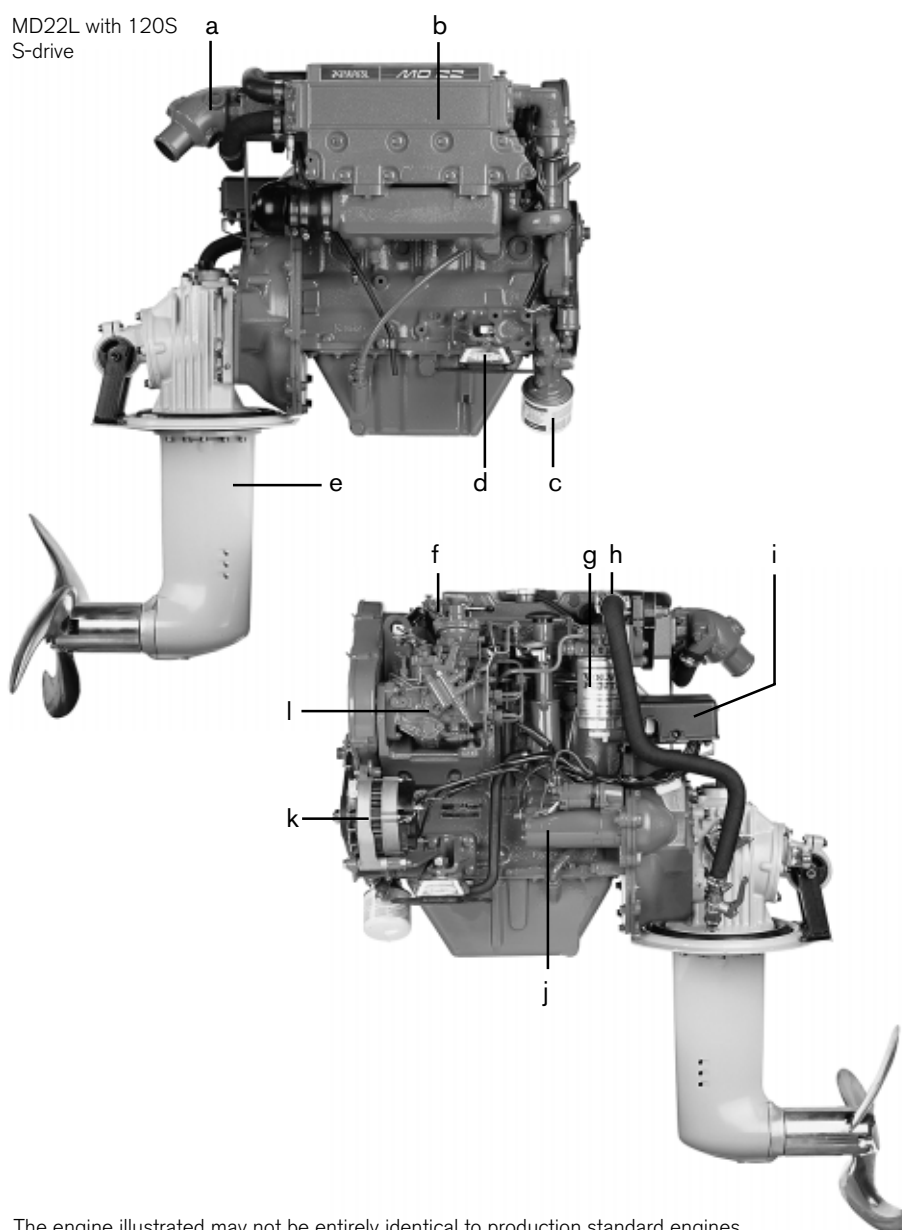

The engine illustrated may not be entirely identical to production standard engines.

- | | |
|--|----------------------------|
| a. Exhaust elbow, wet type | g. Fuel filter |
| b. Heat exchanger with integral expansion tank | h. Seawater pump |
| c. Oil filter | i. Electrical terminal box |
| d. Flexible engine mounting | j. Starter motor |
| e. 120S drive | k. Alternator (GEN) |
| f. Fuel feed pump | l. Injection pump |

VOLVO PENTA

MD22L

Technical Data

Engine designation	MD22L
Crankshaft power kW (hp)	36.5 (50)
Propeller shaft power ¹⁾ , kW (hp)	36 (49)
Full throttle operating speed, rpm	2600–3000
Displacement, l (in ³)	2.0 (122)
Number of cylinders	4
Bore, mm (in.)	84 (3.3)
Stroke, mm (in.)	89 (3.5)
Compression ratio	17:1
Dry weight with reverse gear HS25A, kg (lb)	253 (558)
MS25A, kg (lb)	242 (534)
MS25L, kg (lb)	240 (529)
Dry weight with sail drive S-Drive 120S, kg (lb)	248 (547)

Duty rating: R5–R3

Technical data according to ISO 8665. Fuel with a lower calorific value of 42,700 kJ/kg and density of 840 g/liter at 15°C (60°F). Merchant fuel may differ from this specification which will influence engine power output and fuel consumption.

1) With MS25L

Technical description:

Engine and block

- Cylinder block manufactured from high grade cast iron and cylinder head and pistons of aluminum alloy

- Pistons fitted with two compression rings and a single oil scraper ring
- Overhead camshaft
- Replaceable, hardened valve seats in cylinder head
- Flexible coupling on flywheel

Lubrication system

- Spin-on full flow oil filter
- Separate oil scavenger pipe
- Closed circuit crankcase ventilation

Fuel system

- Flange mounted injection pump of rotor type with mechanical regulator for accurate speed control
- Feed pump with hand primer
- Spin-on type fine fuel filter

Exhaust system

- Freshwater-cooled exhaust manifold and seawater-cooled exhaust elbow

Cooling system

- Freshwater cooling system governed by thermostat and circulation pump
- Tubular heat exchanger with integral expansion tank
- Coolant system prepared for hot water outlet fittings
- Impeller pump for seawater system

Electrical system

- 12V, two-pole, corrosion-protected electrical system
- 14V/60A marine alternator
- Charging regulator with electronic sensor for voltage drop compensation

- Electrically operated stop
- Glow plugs for excellent cold starting
- Electric starter motor (1.8 kW output)
- Extension cable harness with plug-in connection available in various lengths
- Choice of instrument panels or separate instruments

Transmissions:

- **HS25A** Hydraulic – drop center with 8° down angled output shaft. Trolling valve kit available.
- Ratio 2.29:1 and 2.71:1 (RH and LH rotation).

- **MS25A** Mechanical – drop center with 8° down angled output shaft.

- Ratio 2.23:1/2.74:1 (RH/LH) and 2.74:1/2.74:1 (RH/LH).

- **MS25L** Mechanical – drop center with straight output shaft.

- Ratio 2.3:1/2.1:1 (RH/LH) and 2.74:1/2.72:1 (RH/LH).

- **120S – S-drive.**

- Ratio 2.2:1.

Accessories

An extensive range of accessories are available. For detailed information, please see Accessory catalogs. Contact your local Volvo Penta dealer for further information.

Not all models, standard equipment and accessories are available in all countries. All specifications are subject to change without notice.

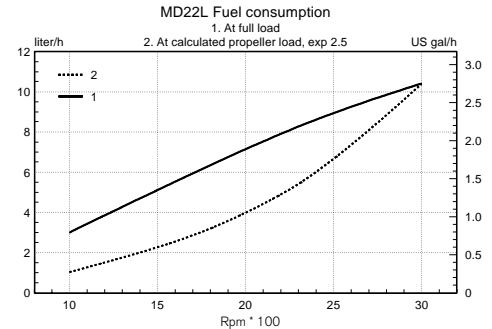
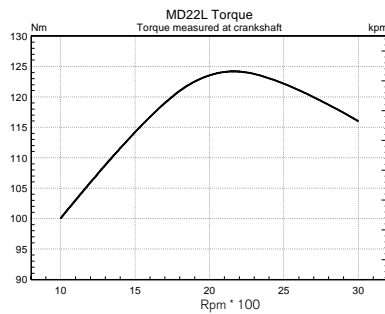
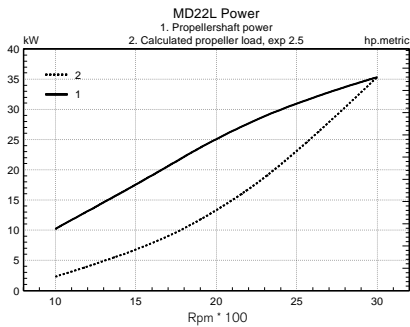

Dimensions MD22L/MS25L/120S

Not for installation

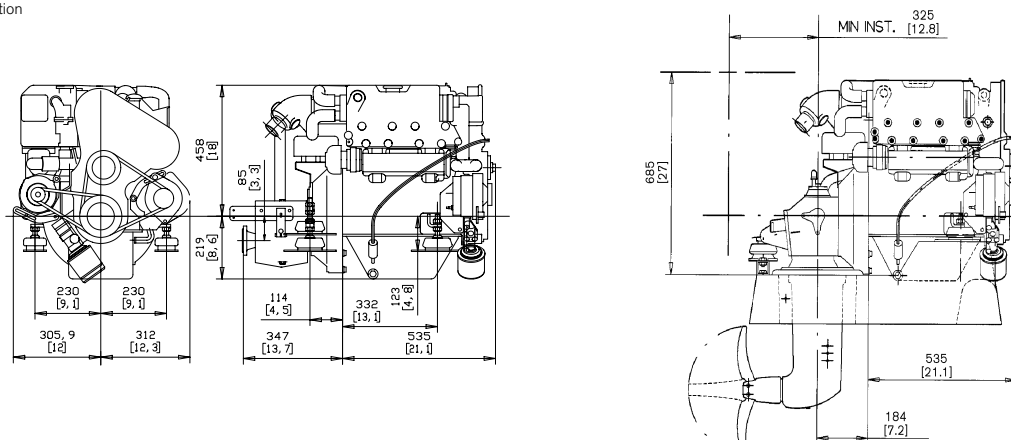

VOLVO PENTA

AB Volvo Penta
SE-405 08 Göteborg, Sweden