

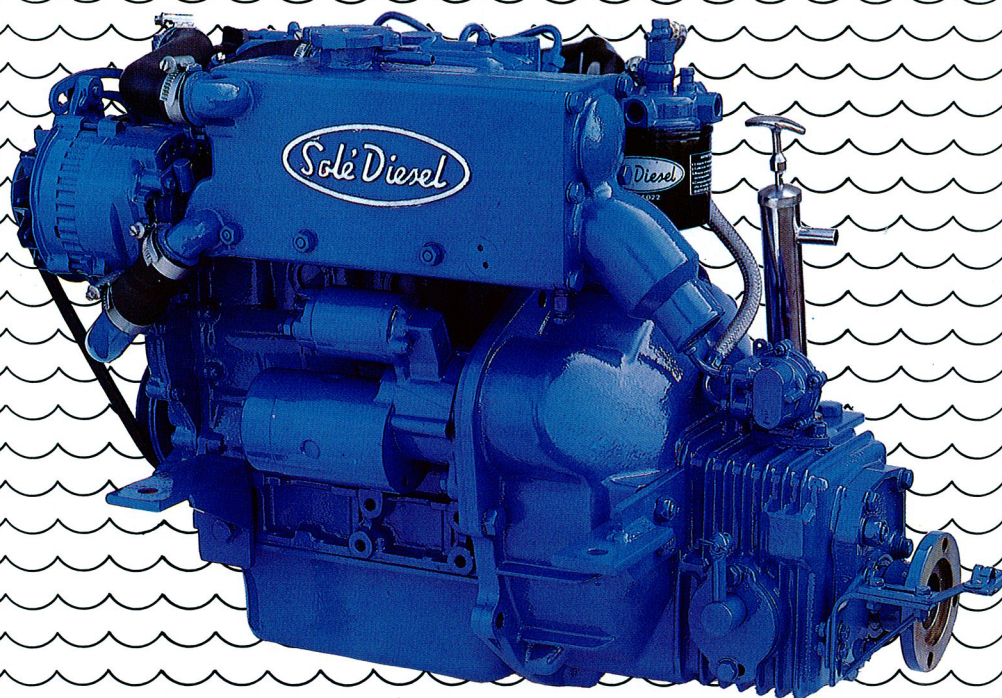

ENGINE

MARINE DIESEL ENGINE MINI-26

BASED ON MITSUBISHI. 3 CYLINDERS 25 HP



Light and compact

These engines are outstanding for their low weight and small size, due to their new compact design and the use of materials such as cast iron and aluminium.

Low vibration and noise level

The small mass of the moving parts, such as pistons, conrods, the new combustion chamber design and indirect injection provide a very low vibration and noise level, as well as clean exhaust gases.

Heat exchanger

The cooling system using a thermostatically controlled heat exchanger keeps the uniform engine temperature at the correct level, therefore providing for longer engine life.

Electrics

12 V starter motor and powerful 12 V 40 A alternator with highly reliable built-in regulator. The engine is delivered complete with electrics. Control panel includes tachometer with hour-counter, audible and visual oil pressure, water temperature and battery charge control alarms, allowing for perfect control of the engine parameters.

MINI-26

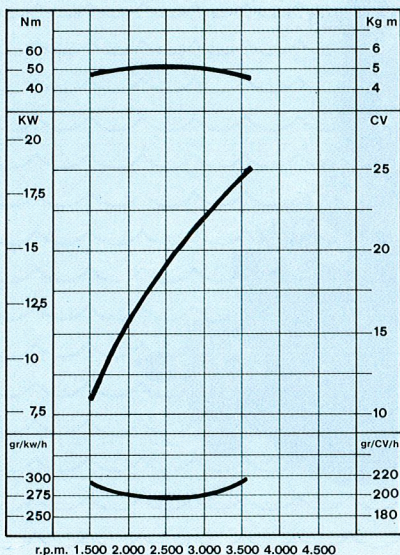
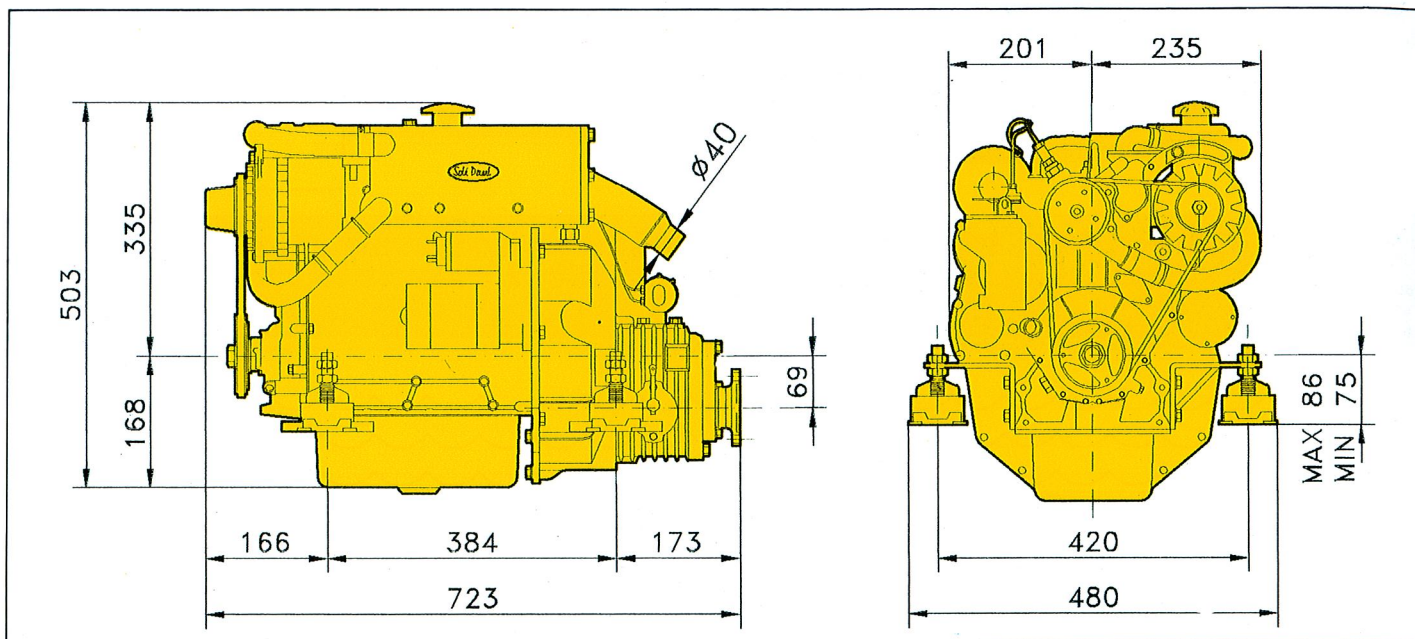

SPECIFICATIONS:

Type	Diesel, 4 stroke.
N.º of cylinders	3 in line
Diameter x stroke mm (in)	76 x 70 (2.99 x 2.76)
Total displacement cc (cu.in.) ..	952 (58.09)
Compression ratio	23:1
Maximum output DIN 6270B..	25 HP (18,4 kw)
Maximum speed	3.600 r.p.m.
Combustion system	Swirl chamber.
Cooling system	Fresh water, using heat exchanger, cooled exhaust manifold.
Electrical system	12 V. starter motor, 1,2 Kw. Alternator 40 A.
Gear box.....	RONIM V type, mechanical, with helical gears.
Reduction ratio	Standard 2,25:1 - Optional 3,05:1
Weight with gear box Kg (lbs.)..	112 (246)
Installation angle	Continuous 20° - Intermittent 25°

Standard equipment:

Electrical starter and alternator, electric stop, control panel with tachometer, hour counter, starter switch, audible alarm for oil and water, oil filter, cooled exhaust manifold, flexible mountings, 3 mts wirings and connection kit for control cables.

Optional equipment:

Waterstrainer, water filter, fuel filter with water separator, remote engine control, propeller shaft, stern tube and propellers.

Specifications are subject to change without prior notice.

IMPORTER:

DEALER: